

Design Patterns in C++

Behavioural Patterns

Giuseppe Lipari

<http://retis.sssup.it/~lipari>

Scuola Superiore Sant'Anna – Pisa

March 13, 2011

What are Behavioural Patterns

- Behavioural patterns describe patterns of message communications between objects
- Therefore, they are concerned with *algorithms*, rather than with *structures*
 - Of course, behavioural patterns are strictly related to structural patterns
- Key observation: how the objects know about each other?
- Main goal: *decouple* objects from each other to allow a dynamic and flexible configurations of algorithms and methods

Outline

- 1 Observer
- 2 Chain of responsibility
- 3 Visitor
- 4 Interpret
- 5 Command
- 6 State
- 7 Strategy

- We need to maintain consistency among (weakly-)related object
 - When something happens to an object, other objects must be informed
- Typical example in GUIs
 - The Document object must be informed when a button “Print” is clicked, so that the print() operation can be invoked
 - The ViewPort object must be informed when the window is resized(), so that it can adjust the visualization of the objects
 - We have already presented an example when presenting the Adapter pattern: an object can “listen” to other objects changes
- Participants:
 - An object changes its state (subject)
 - Another object wants to be informed (observer)

UML Diagram

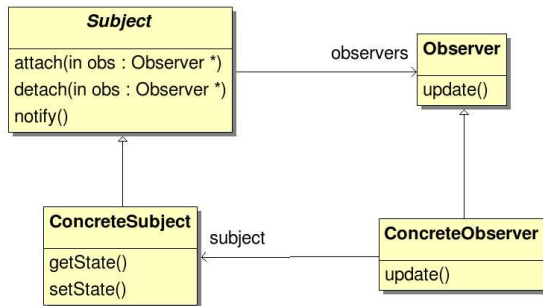

- Subject is the interface for something to be observed
- Observer is thing that observes

Message sequence chart

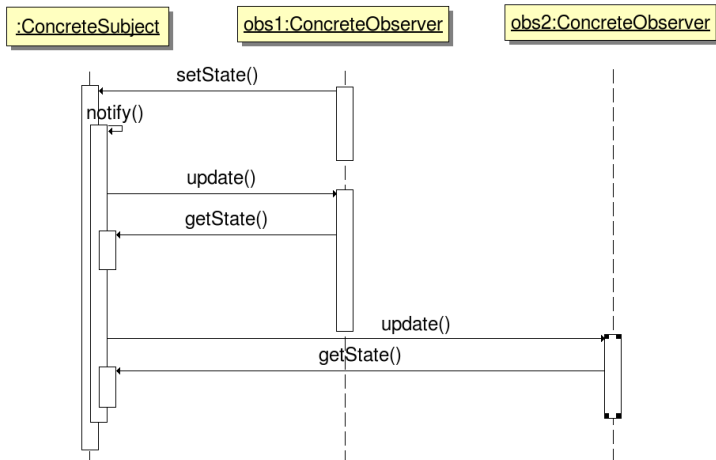

- The user resizes a window:
 - every component of the window needs to be informed of a resize operation (viewport, scrollbars, toolbars, etc.)
 - in this way, every object can synchronize its state with the new window size
- Solution:
 - The window can install *observers*
 - All components (viewport, scrollbar, etc.) can attach an observer to the main window that is informed when a resize operation is under way
 - The observer asks for the current size of the window, and invoke methods on the objects to adjust their state (size)

- **Abstract coupling** between subject and observer
 - all that a subject knows is that there is a list of observers, but it does not know anything about the observers themselves
 - the observer instead must know the subjects
- **Broadcast communication**
 - There can be many independent observers, with different purposes and hierarchies
 - *Example*: resizing a window can affect the viewports inside the window, the scrollbars, etc.

- **Abstract coupling** between subject and observer
 - all that a subject knows is that there is a list of observers, but it does not know anything about the observers themselves
 - the observer instead must know the subjects
- **Broadcast communication**
 - There can be many independent observers, with different purposes and hierarchies
 - *Example*: resizing a window can affect the viewports inside the window, the scrollbars, etc.
- **Unexpected updates**
 - A seemingly innocuous operation on the subject may cause a cascade of updates on the observers and their dependent objects, many of them may not care about any update
 - This simple protocol does not tell the observer *what* change happened to the subject (a resize? a move?)

● Pull model

- the subject sends nothing
- the observer asks for details about the changes
- equivalent to what we have already seen

● Push model

- the subject sends the observer detailed information about the change (whether it wants it or not)
- the observer can understand if he is interested in the change by analysing this additional parameter

● Specifying events

- By complicating the protocol, it is possible to register to specific aspects
 - onResize()
 - onMove(),
 - ...
- more efficient, but more complex interface

- It is possible to efficiently and effectively use templates for extending as much as possible to usage of the observer pattern
- the first extension we consider is to have an observer that wants to observe different subjects
 - however, in the standard patterns, only one subject is possible
 - we could have different pointers inside the ConcreteObserver class, however the update takes no parameter
 - to understand which subject has changed, we need to pass a parameter to the update
 - we could pass a simple integer, 0 meaning the first subject, 1 the second subject, and so on
 - however, the subject must know its number for the specific observer; and the observer has to implement a switch case
 - not very scalable
- My solution is to use one more class, that *connects* subject with observer

UML diagram

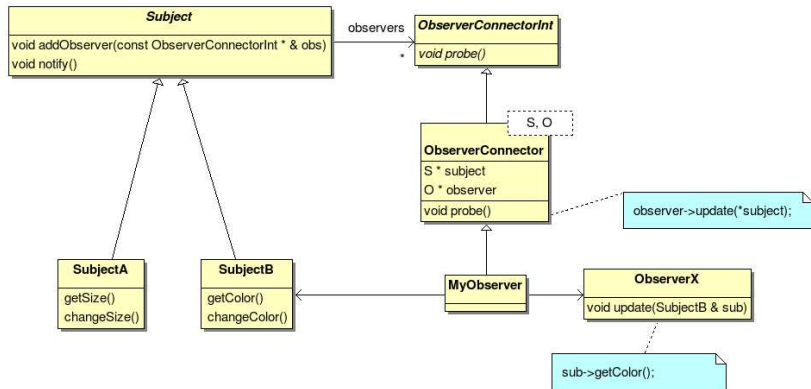

- See the code in observer example

Outline

- 1 Observer
- 2 Chain of responsibility**
- 3 Visitor
- 4 Interpret
- 5 Command
- 6 State
- 7 Strategy

Motivation

- Consider a context-sensitive “help” for a GUI
 - the user can click on any part of the interface and obtain help on it
- The help that is actually provided depends on
 - which part of the interface (button, menu, etc.)
 - the context (where the button is)
- Example:
 - a button in a dialog box
 - a button in the main window
- If no help can be found for that part, a more general help page is shown

Motivation

- Consider a context-sensitive “help” for a GUI
 - the user can click on any part of the interface and obtain help on it
- The help that is actually provided depends on
 - which part of the interface (button, menu, etc.)
 - the context (where the button is)
- Example:
 - a button in a dialog box
 - a button in the main window
- If no help can be found for that part, a more general help page is shown
- The help should be organized hierarchically
 - From more general to more specific
- The object that provides the help is not known to the object that initiates the request for help
 - the button does not know which help object will handle the request, as this depends on the context

Goals and requirements

- Decouple senders and receivers
- Gives multiple objects a chance to handle the request
- Chain:
 - build a list of receivers
 - pass the request to the first receiver
 - if the request cannot be handled, pass it to the next receiver in the chain
- Consequences
 - *Reduced coupling*: the sender does not care which object handles the request
 - *Added flexibility in assigning responsibility*: different responsibility can be distributed to different objects
 - *Receipt is not guaranteed*: there is not guarantee that eventually some object will handle the request

UML diagram

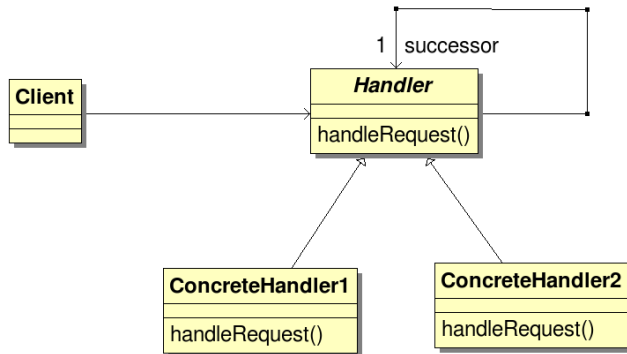

Example Instance

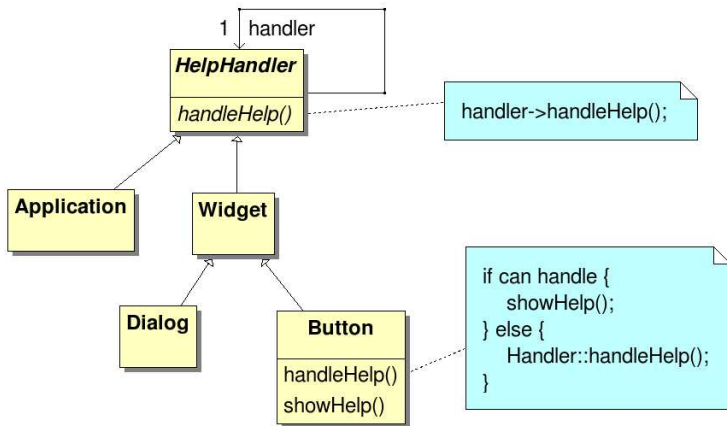

- **Applicability**

- More than one object can handle a request, and the handler is not known a priori
- you want to issue a request to one of several objects without specifying the receiver explicitly
- the set of objects that can handle a request should be specified dynamically

- **Implementation**

- *Connecting successors*: the `Handler` class itself usually maintains a link to the successor. Also, it automatically forwards allow requests by default if there is a successor.
- *Representing requests*: usually represented in the method call itself (i.e. `handleHelp()`). However, we could think of one or more parameters to encode the specific request.
- to simplify the passage of parameters, we could also encode them into an object that is passed along the chain

Outline

- 1 Observer
- 2 Chain of responsibility
- 3 Visitor**
- 4 Interpret
- 5 Command
- 6 State
- 7 Strategy

- Consider a compiler that internally represents a program as an abstract syntax tree
 - the compiler will take as input a text file containing the program
 - the *parser* component will read the file and build the syntax tree
 - then it performs syntax checking on the tree
 - for example, it checks that all used variables have actually been defined, and that the type corresponds
 - it will also need to generate code
 - optionally, it can need to print the program in a nice formatted way
- In general, on a complex structure, you may need to define several distinct operations
- The structure may consists of different types of nodes (see the `Composite` pattern)

Naive approach

- Let's define a method for each operation in the node itself

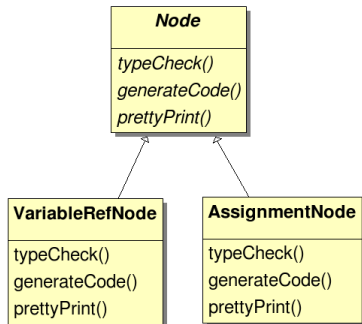

Naive approach

- Let's define a method for each operation in the node itself

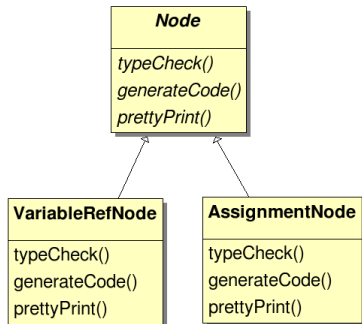

- Not correct. Why?

The problem

- Does not scale: what if we want to implement one more operation to visit the node?
 - We need to change all the `Node` classes
- Also, we are doing many things to do in a single class
 - The `Node` class should care about the structure, and to provide a generic interface to all types of nodes
 - `Node` typically implements a **Composite** pattern
- What we need to do
 - Decouple visiting from Nodes.
 - Solution: use a different class to encapsulate the various visiting operations

The Visitors

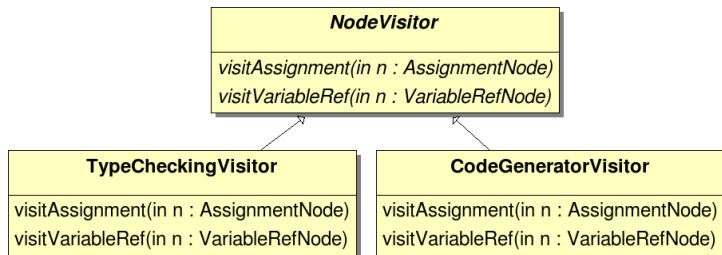

- These classes take care of visiting the Nodes, and doing the appropriate operations
- each concrete visitor implements a different kind of visit

The Nodes to be visited

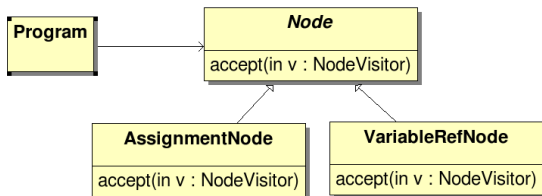

- Now the `Node` class is much simpler
- it only needs to provide a *hook* for allowing visitors to visit it

Generic UML diagram

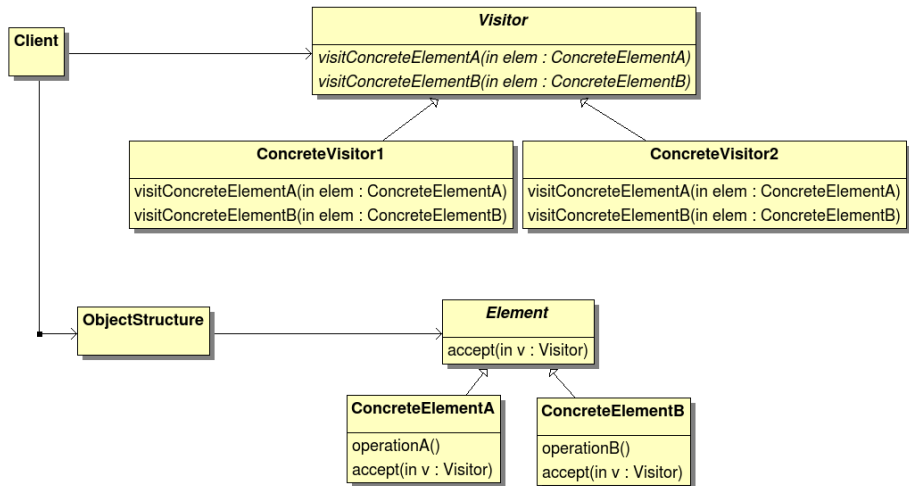

Message Sequence Chart

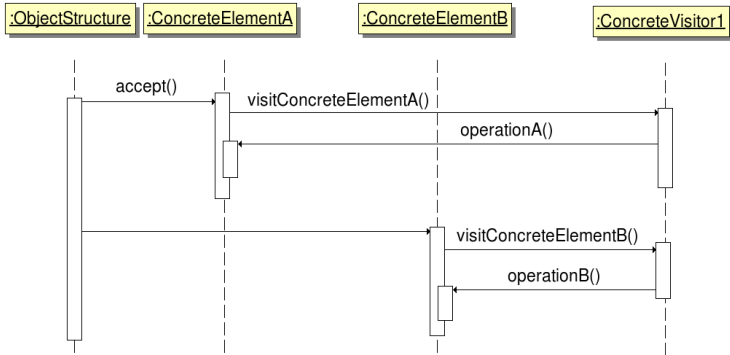

- Use the Visitor pattern when
 - an object structure contains many classes of objects with different interfaces, and you want to perform operations on the elements of the structure
 - many different operations needs to be performed on objects in a structure, and you want to avoid putting such operations on the objects (decoupling)
 - the classes defining the object structure rarely or never change

- *Visitor makes adding new operations easier*
- *Adding a new ConcreteElement is hard*
- similar to an `Iterator`, however the `Iterator` visits elements of the same type, while visitor traverses structure of objects of different types
- *Accumulating State*: since the visitor is an object, while visiting it can accumulate state, or cross-check the structure

Implementation techniques

- The visitor is able to understand the type of the element it is visiting using the technique called **double dispatch**.
- Single dispatch:
 - the operation to be invoked depends on the type of the object (or of the pointer), and on the parameter list
 - in object oriented slang, we say that it depends on the message type (the method) and on the receiver (the object) type
- Double Dispatch:
 - The operation that is invoked depends on the message type (the method) and on *two* receivers
 - *accept()* is a double-dispatch operation, because the final method that is called depends both on the visitor type and the element type
 - the technique used for the template observer is quite similar: which operation is invoked depends on the message type (update), on the receiver (the observer) and on the subject (parameter of the update)

Who performs the visit?

- Different techniques
 - The object structure
 - the Visitor
 - A separate object (an Iterator)

Outline

- 1 Observer
- 2 Chain of responsibility
- 3 Visitor
- 4 Interpret**
- 5 Command
- 6 State
- 7 Strategy

Given a language, define a representation for its grammar along with an interpreter that uses the representation to interpret sentences in the language

- In many cases it is useful to define a small language to define things that need to be expressed easily
- Examples where a simple language may be useful
 - Configuration files for creating objects
 - List of complex parameters
 - Rules to configure filters, etc.
- If the language is complex (for example, a scripting or programming language), it is better to use classical tools like parser generators
- However, when we want to implement a simple thing, then it may be useful to do it by hand in C
- In the following example, we will assume to build a simple interpreter for regular expressions

- Grammar rules

```
expression ::= literal | alternation | sequence | repetition |  
            '(' expression ')'  
alternation ::= expression '|' expression  
sequence   ::= expression '&' expression  
repetition ::= expression '*'  
literal    ::= 'a' | 'b' | 'c' | ... { 'a' | 'b' | 'c' | ... }*
```

- Expression is the starting rule
- Literal is a *terminal* symbol

- To implement the previous grammar, we prepare a class for each rule
- each class derives from an abstract class
- at the end of the parsing we must obtain an *abstract syntax tree* that will represent the expression

UML representation

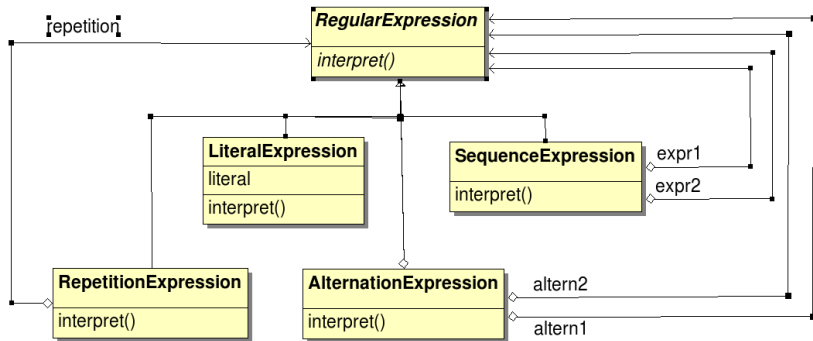

How the interpret works

- The abstract syntax tree must be built by a parser (not part of this pattern)
- once the tree is built, we can use it in our program.
 - For example, we could pass the interpret a sequence of characters, and it will tell us if the sequence respects the regular expression
 - we would also pretty-print the expression, or transform it into another representation (for example a finite state machine)

- A general UML representation is the following

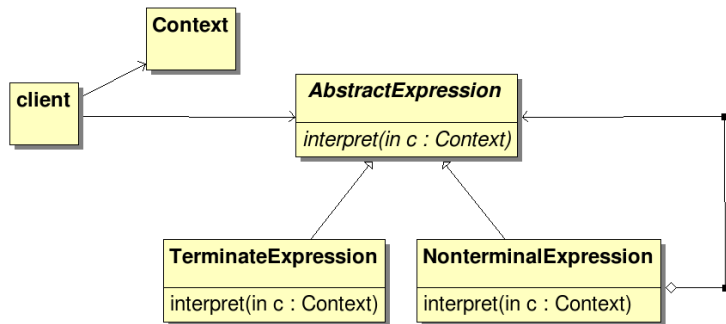

- **AbstractExpression** (RegularExpression)
 - it represents the abstract interface for the node in the tree
- **TerminalExpression** (LiteralExpression)
 - Represents the leaf of the tree, cannot be further expanded
- **NonTerminalExpression** (SequenceExpression, AlternationExpression, etc.)
 - this class represents a rule in the grammar
 - it is also an intermediate node in the tree, can contain children
- **Context**
 - Contains global information useful for the interpret
- **Client**
 - builds the abstract syntax tree via a parser
 - calls the interpreter operation to carry on the interpretation of the language

Consequences

- *It's easy to change and extend the grammar*
 - appropriate classes can be written, existing classes appropriately modified
- *Easy to implement the grammar*
 - Classes are easy to write and often their generation can be automated by a parser generator
- *Complex grammars are hard to maintain*
 - When the number of rules is large, you need a lot of classes
 - also, not very efficient to execute
- Adding new ways to interpret expressions
 - Since you have the tree, you can do many things with it
 - by using a Visitor pattern, you can easily add new operations without modifying the classes

- In the code

Outline

- 1 Observer
- 2 Chain of responsibility
- 3 Visitor
- 4 Interpret
- 5 Command**
- 6 State
- 7 Strategy

- Sometimes it is necessary to issue requests to objects without knowing anything about the operation being requested, or the receiver of the request
 - Example: when pressing a button, something happens that is not related or implemented to the Button class
 - In many cases, exactly the same operation can be performed by a menu item, or by a button in a toolbar
- We want to encapsulate commands into *objects*
- This patterns is the OO equivalent of C *callbacks*
- Other uses
 - Undo/redo of commands
 - Composing commands (macros)

UML example

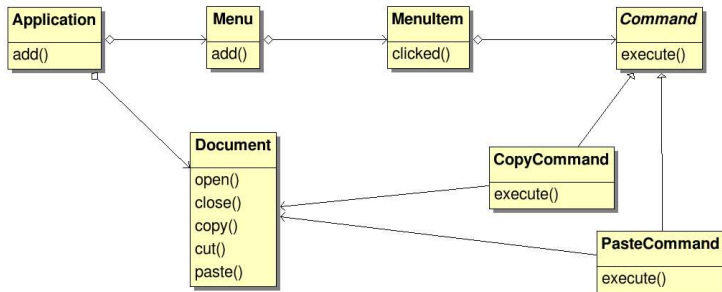

Implementing macros

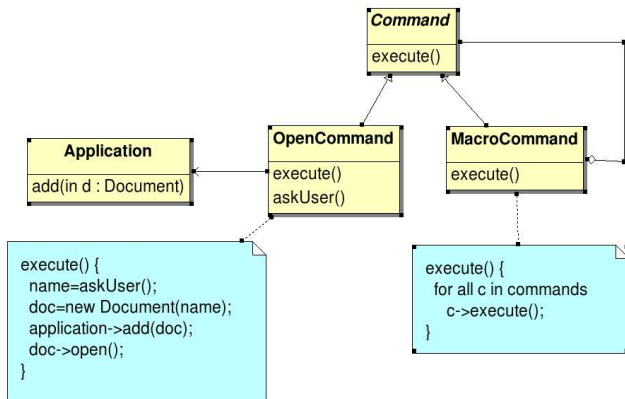

General UML structure

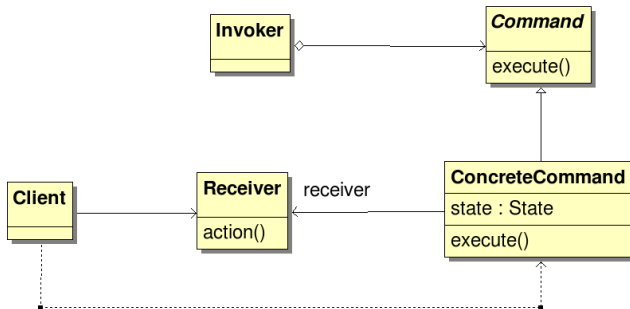

- It is not always possible
 - The operation should be reversible
 - Need to add and undo() operation in the Command abstract class
 - The command may need to carry additional state of the receiver inside
 - We need an history list (how far should we go with the history?)
- Using prototype
 - We could use a Prototype pattern to create copies of commands, customize with the internal state of the receiver, and then save the copy on the history

- Commands are objects, not just functions
 - They can carry state information on the receivers
 - They can carry information on the history itself
- The Invoker only needs to know the general interface of the command (execute()), not the specific internal information (i.e. parameters, etc.) which are decided at creation time

Outline

- 1 Observer
- 2 Chain of responsibility
- 3 Visitor
- 4 Interpret
- 5 Command
- 6 State**
- 7 Strategy

The State pattern

Allow an object to alter its behaviour when its internal state changes. The object will appear to change its class.

- This pattern is useful to implement simple state machines
- The idea is to implement each state with a different class, and each event with a different method
- Consider a library to implement the TCP protocol
 - A TCPConnection can be in one of several different states
 - For example, the connection can be void, established, closing, etc.
 - the response to a request of open depends on the current state of the connection: only if the connection is not yet established we can open it
- this behaviour can be implemented as follows:
 - An abstract class TCPState that implements a method for each possible request
 - the derived classes represent the possible states
 - only some of them will respond to a certain request

Example

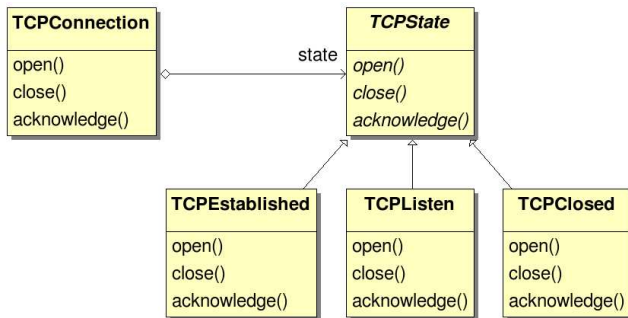

- Use the State pattern in one of the following cases
 - an object behaviour depends on its state, that will change at run-time
 - operations have large, multi-part, conditional statements that depend on the object state. This state is usually represented by one or more enumerated constants

UML diagram

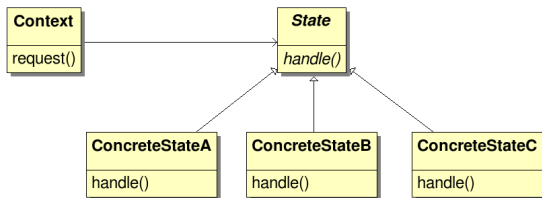

- **Context** (TCPConnection)
 - defines the interface of interest to clients
 - maintains an instance of a **ConcreteState** subclass that defines the current state through a pointer to the abstract **State** class
- **State** (TCPState)
 - defines an interface for encapsulating the behaviour associated with a particular state of the **Context**
- **ConcreteState** subclasses
 - each subclass implements a behaviour associated with a state of the **Context**

- *Localizes state-specific behaviour and partitions behaviour for different states.*
 - All behaviour associated with a particular state is concentrated into a single class (ConcreteState).
 - new states and transitions can be easily added
 - the pattern then avoids large if/then/else conditional instructions
 - however, distributing information in state classes may not be appropriate for complex behaviour, because it increases the amount of interaction and dependencies between classes
- *it makes state transitions explicit.*
 - a transition is a change in the state object, therefore is quite visible

Outline

- 1 Observer
- 2 Chain of responsibility
- 3 Visitor
- 4 Interpret
- 5 Command
- 6 State
- 7 Strategy**

Define a family of algorithms, encapsulate each one, and make them interchangeable. Strategy lets the algorithms vary independently from clients that use it

- In general, it is useful to delegate an algorithm to a function, instead of embedding it into the normal code
 - we make the algorithm general and reusable
 - we can easily change the algorithm by substituting the function
- In object oriented programming, objects can be used instead of functions
- An example:
 - many algorithms exist for breaking a stream of text into lines
 - hard-wiring them into the class that uses them is undesirable, because it goes against the single-responsibility principle
 - therefore, we could define an hierarchy of “function objects” that behave like functions

UML diagram

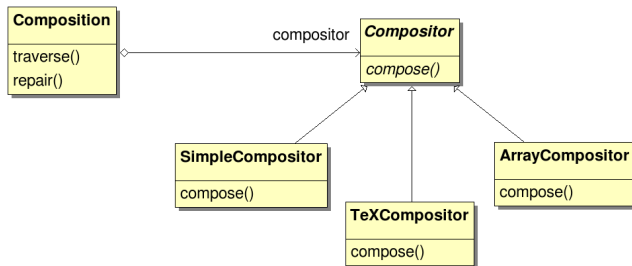

- **SimpleCompositor** implements a simple strategy that determines linebreaks one at a time
- **TeXCompositor** implements the TeX algorithm for finding linebreaks. This strategy tries to optimize linebreaks globally, that is one paragraph at a time
- **ArrayCompositor** implements a strategy that selects breaks so that each row has a fixed number of items. It's useful for breaking a collection of icons into rows, for example

- **SimpleCompositor** implements a simple strategy that determines linebreaks one at a time
- **TeXCompositor** implements the TeX algorithm for finding linebreaks. This strategy tries to optimize linebreaks globally, that is one paragraph at a time
- **ArrayCompositor** implements a strategy that selects breaks so that each row has a fixed number of items. It's useful for breaking a collection of icons into rows, for example
- A Composition maintains a reference to a Compositor object
- we can change strategy both at compile time and at run-time
- Why using classes instead of functions?
 - Objects can carry state, while functions can't

- In C++ you can define a method without name, through the `operator()`

```
class MyFunctor {
    ...
public:
    MyFunctor();
    double operator() {...}
    ...
};

MyFunctor a;
...
double result = a();
// equivalent to
// result = a.operator();
```

- You can also pass parameters to the operator, and overload it

- Using this technique, a class can be easily parametrised through a template instead than by inheritance

```
template <class Functor>
class Context {
    Functor f;
public:
    ...
    void operation() {
        f();
    }
};
```