

Real-Time Compute Virtualization

Luca Abeni

`luca.abeni@santannapisa.it`

March 30, 2026

Real-Time Applications

- Real-Time Application: The **time** when a result is produced **matters**
 - A correct result produced *too late* is equivalent to a wrong result (or to no result)
- What does “*too late*” mean, here?
 - Applications characterised by **temporal constraints** that have to be respected!
- Examples:
 - Control applications, autonomous driving, ...
 - But also infotainment, gaming, telecommunications, ...!!!

Temporal Constraints

- Temporal constraints are modelled through *deadlines*
 - Finish some activity before a time (deadline)
 - Generate some data before a deadline
 - Terminate some process/thread before a deadline
 - ...
- What happens if a constraint is not respected?
 - Simple: the application **fails!**

Processes, Threads, and Tasks

- Algorithm → logical procedure used to solve a problem
- Program → formal description of an algorithm, using a *programming language*
- Process → instance of a program (program in execution)
 - Program: static entity
 - Process: dynamic entity
- The term *task* is used to indicate a schedulable entity (either a process or a thread)
 - Thread → flow of execution
 - Process → flow of execution + private resources (address space, file table, etc...)

Real-Time Tasks

- A **task** can be seen as a **sequence of actions** . . .
- . . . and a deadline must be associated to each one of them!
 - Some kind of formal model is needed to identify these “actions” and associate deadlines to them

Mathematical Model of a Task - 1

- Real-Time task τ_i : stream of jobs (or instances) $J_{i,k}$
- Each job $J_{i,k} = (r_{i,k}, c_{i,k}, d_{i,k})$:
 - Arrives at time $r_{i,k}$ (activation time)
 - Executes for a time $c_{i,k}$
 - Finishes at time $f_{i,k}$
 - Should finish within an **absolute deadline** $d_{i,k}$

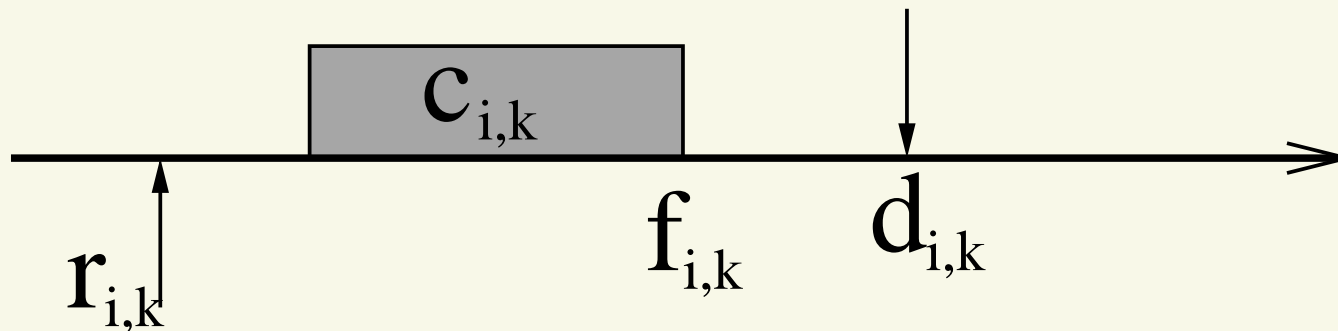

Mathematical Model of a Task - 2

- Job: abstraction used to associate deadlines (temporal constraints) to activities
 - $r_{i,k}$: time when job $J_{i,k}$ is *activated* (by an external event, a timer, an explicit activation, etc...)
 - $c_{i,k}$: computation time needed by job $J_{i,k}$ to complete
 - $d_{i,k}$: absolute time instant by which job $J_{i,k}$ must complete
 - job $J_{i,k}$ respects its deadline if $f_{i,k} \leq d_{i,k}$
- Response time of job $J_{i,k}$: $\rho_{i,k} = f_{i,k} - r_{i,k}$

RT Scheduling: Why?

- The task set $\mathcal{T} = \{(1, 3), (4, 8)\}$ is not schedulable by FCFS

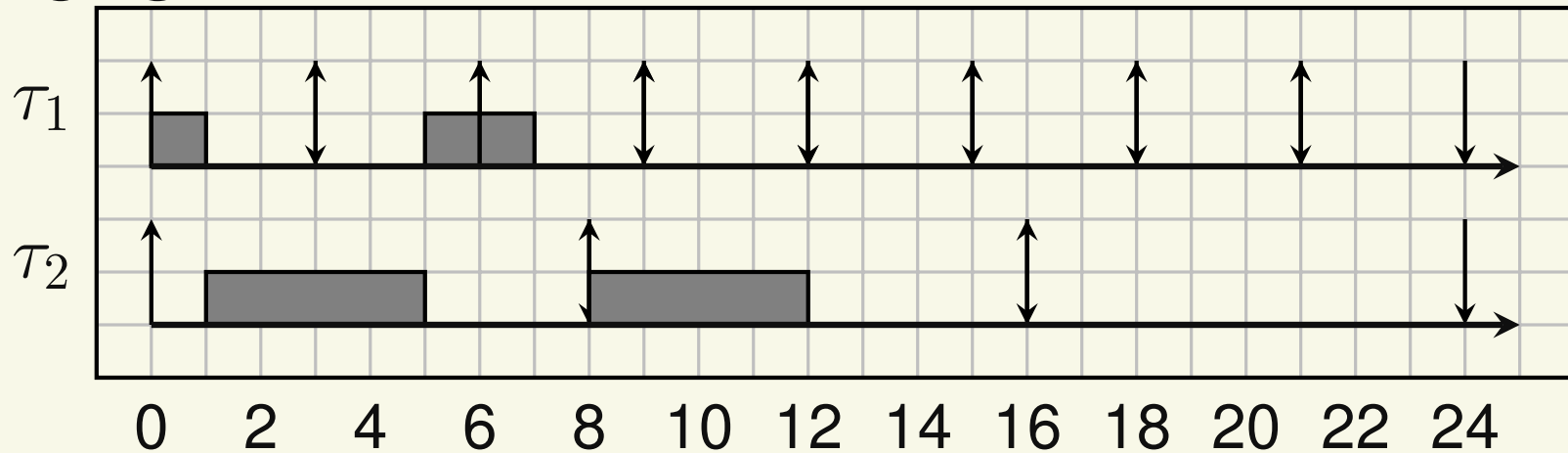

- $\mathcal{T} = \{(1, 3), (4, 8)\}$ is schedulable with other algorithms

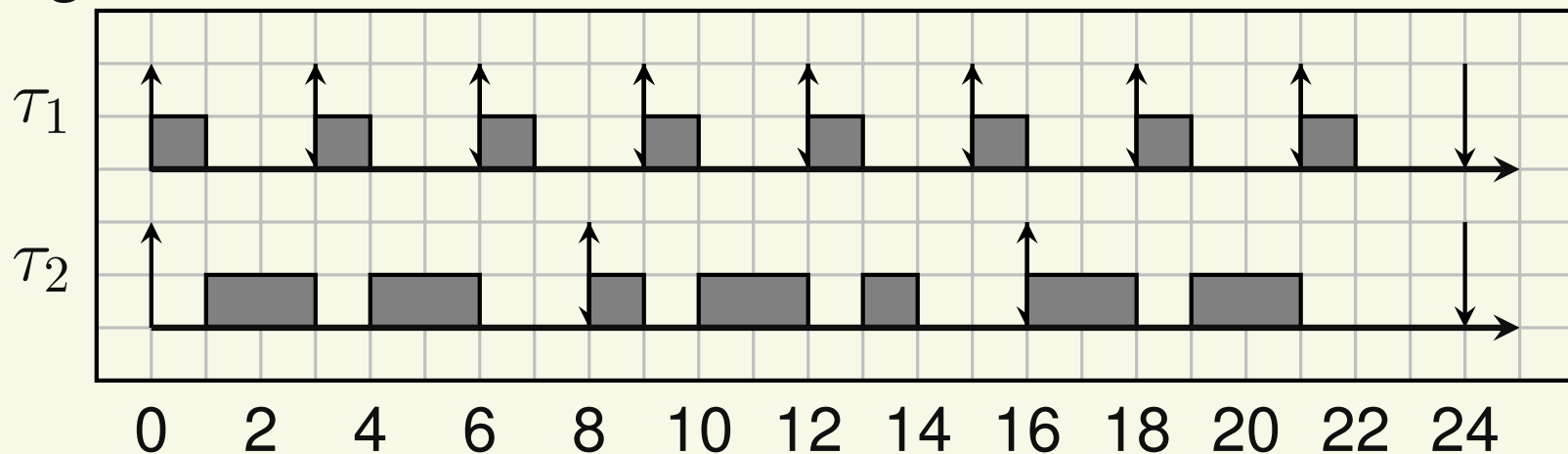

The Scheduling Problem

- A real-time task τ_i is properly served if all jobs respect their deadline...
- ...Appropriate scheduling is important!
 - The CPU scheduler must somehow know the temporal constraints of the tasks...
 - ...To schedule them so that such temporal constraints are respected
- How to schedule real-time tasks? (scheduling algorithm)
- Is it possible to respect all the deadlines?
- Do commonly used OSs provide appropriate scheduling algorithms?

Fixed Priority Scheduling

- Very simple *preemptive* scheduling algorithm
 - Every task τ_i is assigned a fixed priority p_i
 - The active task with the highest priority is scheduled
- Priorities are integer numbers: the higher the number, the higher the priority
 - In the research literature, sometimes authors use the opposite convention: the lowest the number, the highest the priority
- In the following we show some examples, considering periodic tasks, constant execution times, and deadlines equal to the period

Example of Schedule

- Consider the following task set: $\tau_1 = (2, 6, 6)$, $\tau_2 = (2, 9, 9)$, $\tau_3 = (3, 12, 12)$. Task τ_1 has priority $p_1 = 3$ (highest), task τ_2 has priority $p_2 = 2$, task τ_3 has priority $p_3 = 1$ (lowest)

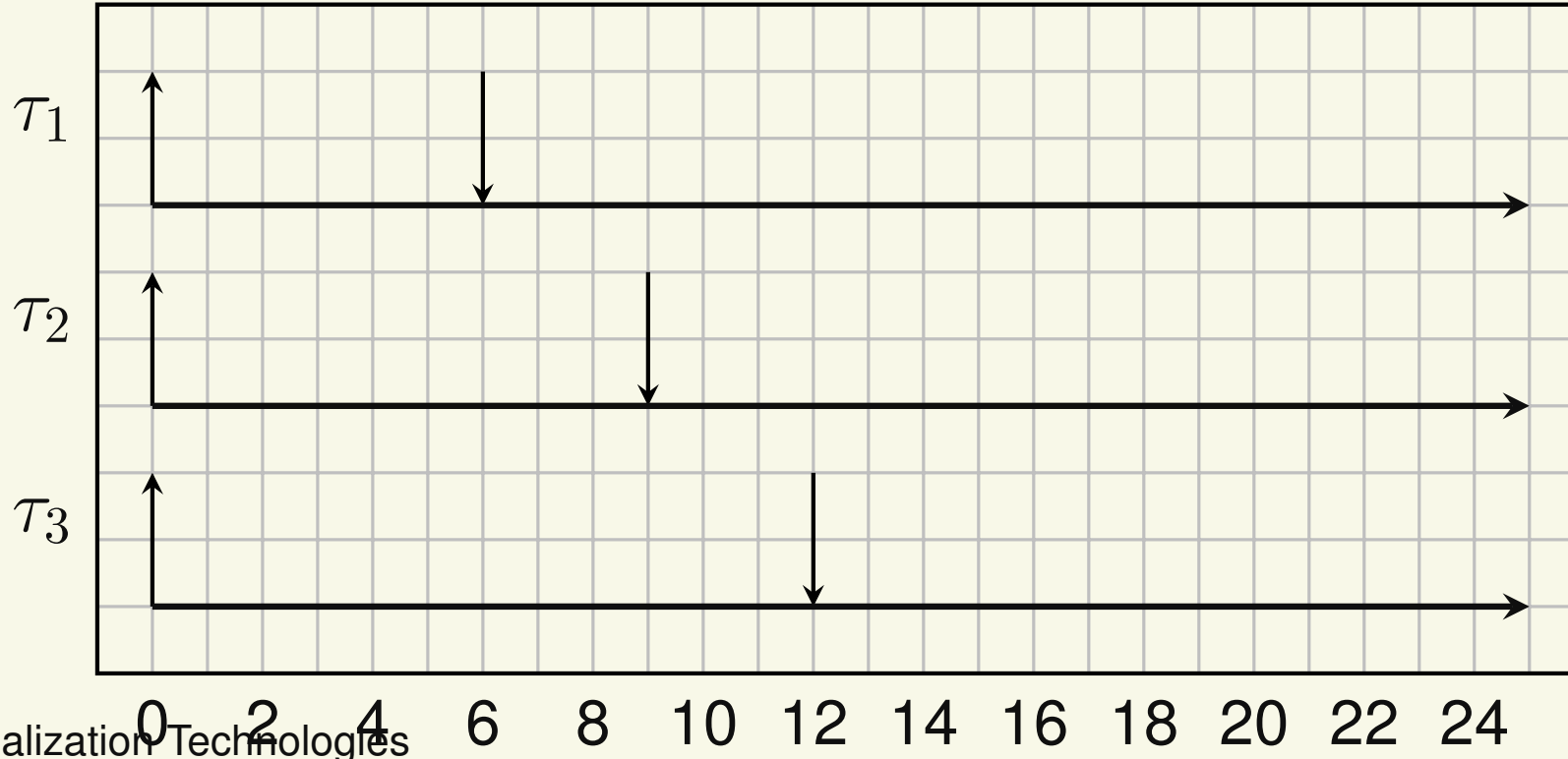

Example of Schedule

- Consider the following task set: $\tau_1 = (2, 6, 6)$, $\tau_2 = (2, 9, 9)$, $\tau_3 = (3, 12, 12)$. Task τ_1 has priority $p_1 = 3$ (highest), task τ_2 has priority $p_2 = 2$, task τ_3 has priority $p_3 = 1$ (lowest)

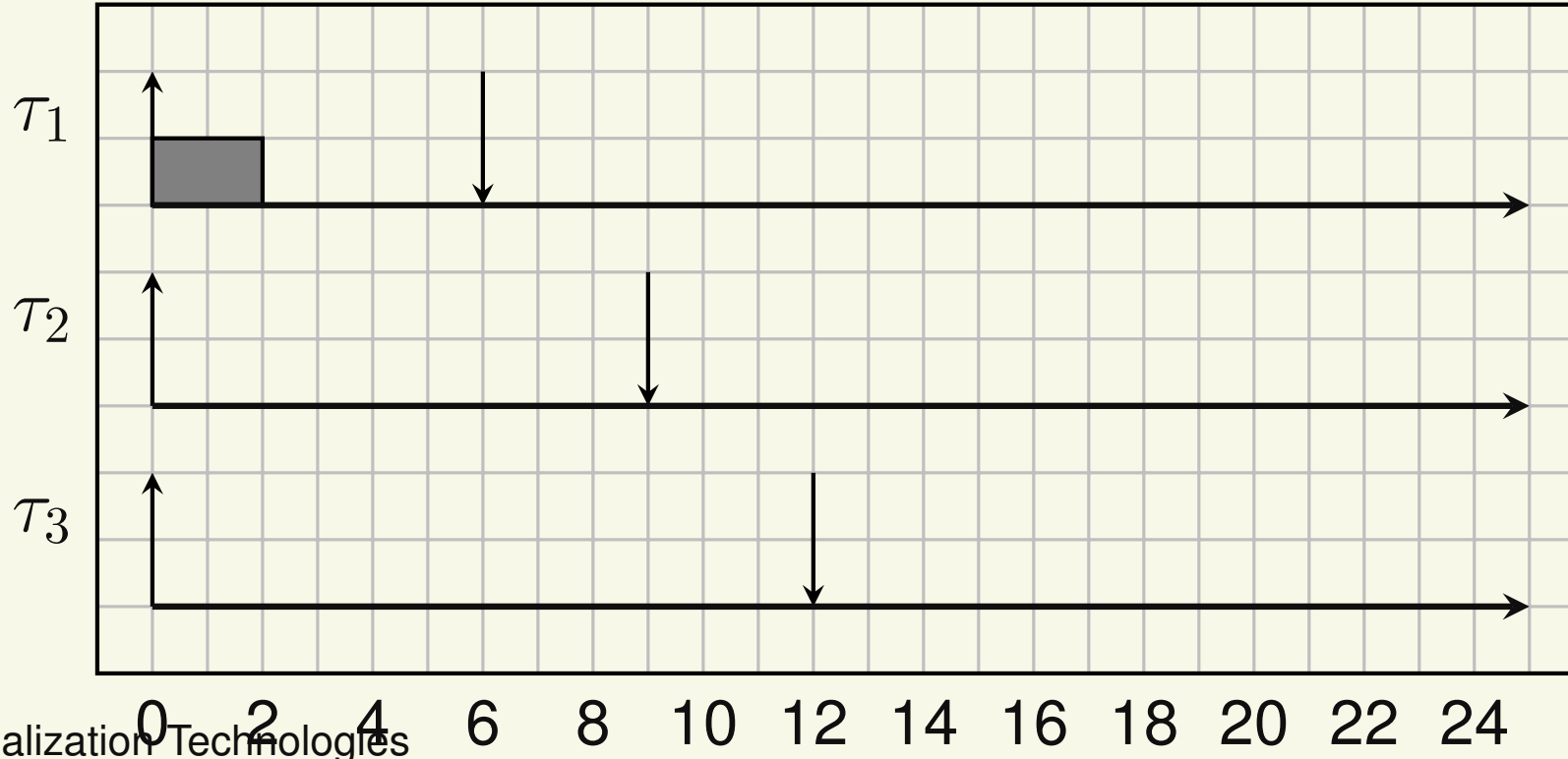

Example of Schedule

- Consider the following task set: $\tau_1 = (2, 6, 6)$, $\tau_2 = (2, 9, 9)$, $\tau_3 = (3, 12, 12)$. Task τ_1 has priority $p_1 = 3$ (highest), task τ_2 has priority $p_2 = 2$, task τ_3 has priority $p_3 = 1$ (lowest)

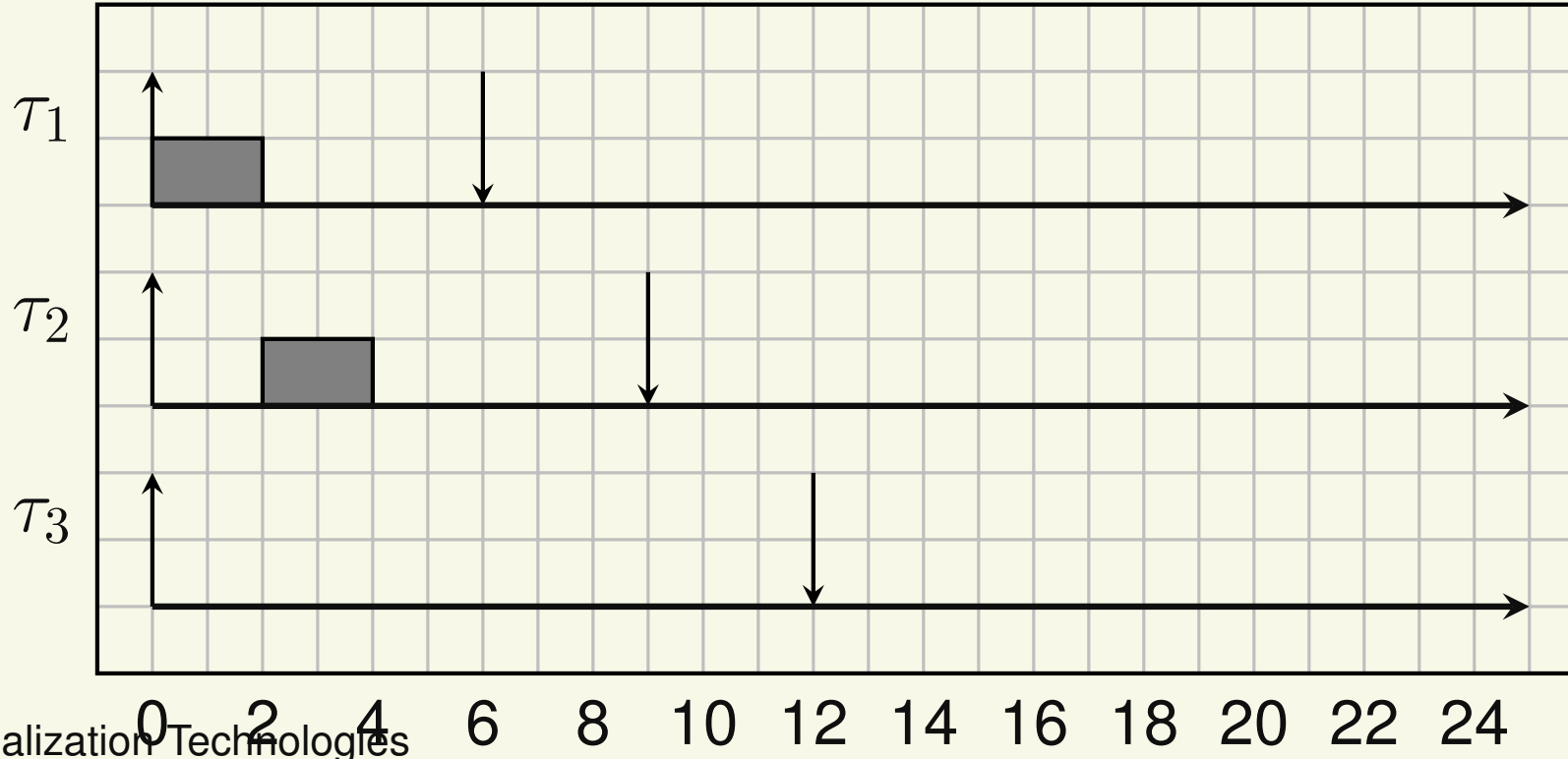

Example of Schedule

- Consider the following task set: $\tau_1 = (2, 6, 6)$, $\tau_2 = (2, 9, 9)$, $\tau_3 = (3, 12, 12)$. Task τ_1 has priority $p_1 = 3$ (highest), task τ_2 has priority $p_2 = 2$, task τ_3 has priority $p_3 = 1$ (lowest)

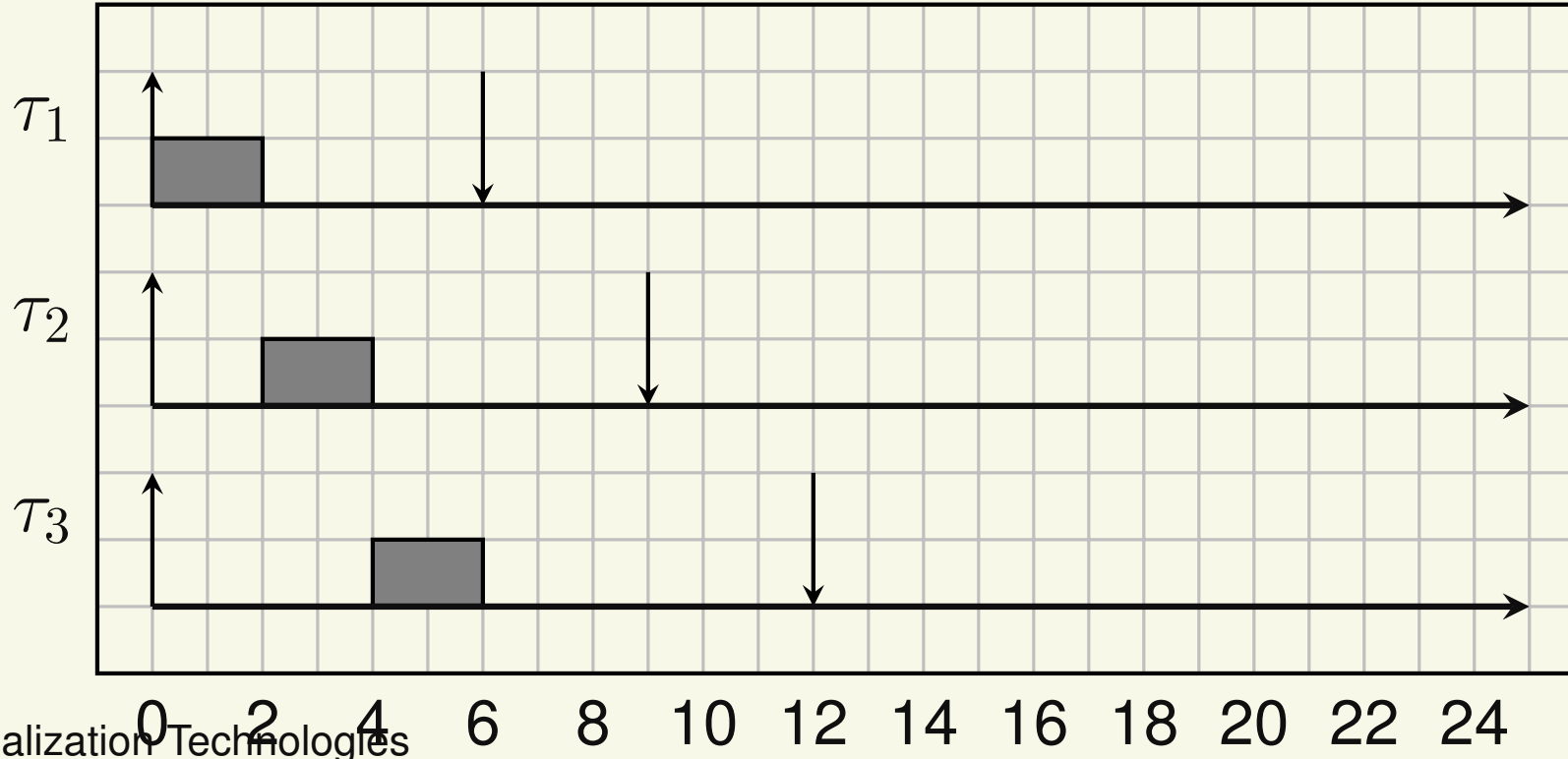

Example of Schedule

- Consider the following task set: $\tau_1 = (2, 6, 6)$, $\tau_2 = (2, 9, 9)$, $\tau_3 = (3, 12, 12)$. Task τ_1 has priority $p_1 = 3$ (highest), task τ_2 has priority $p_2 = 2$, task τ_3 has priority $p_3 = 1$ (lowest)

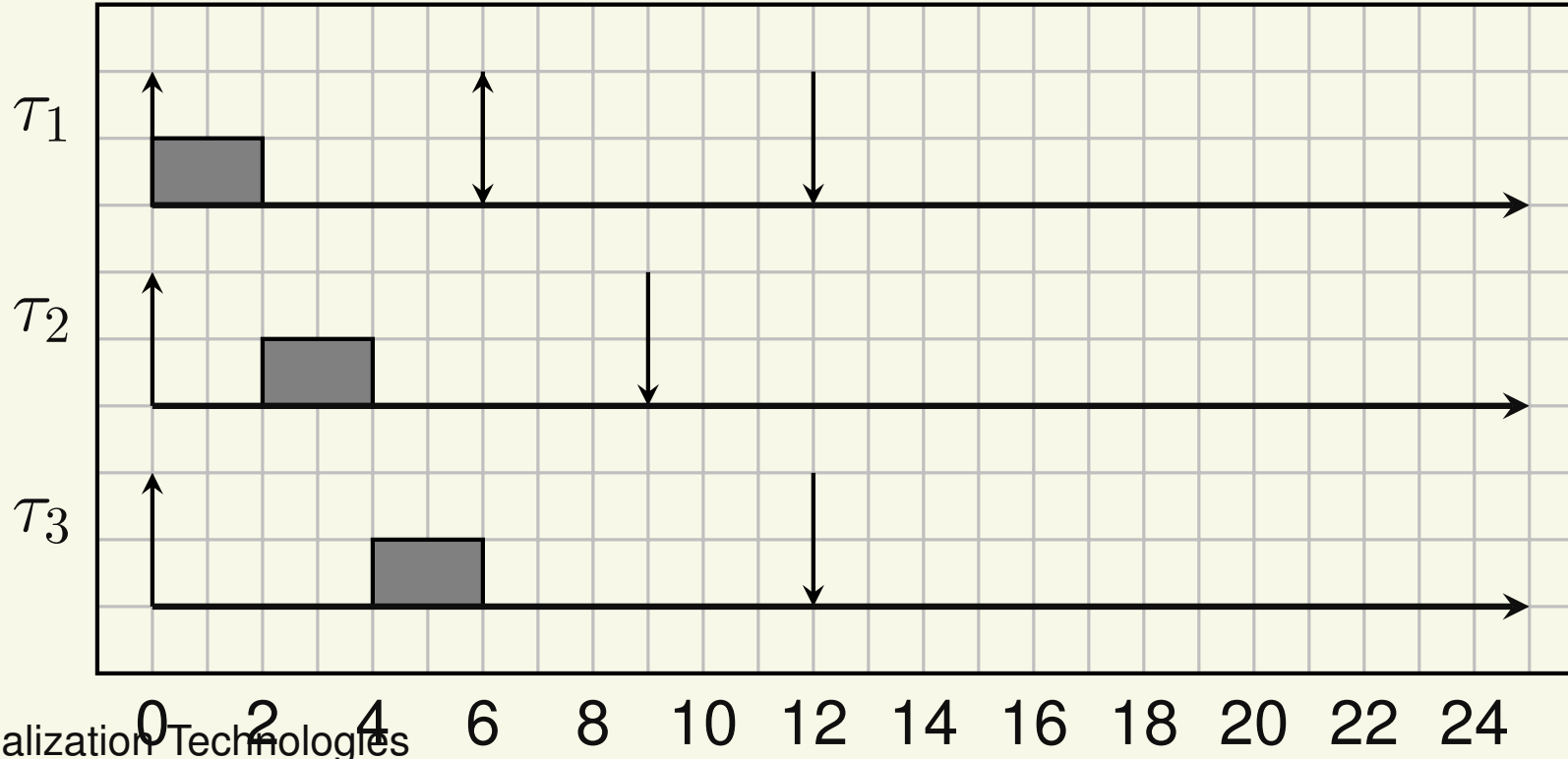

Example of Schedule

- Consider the following task set: $\tau_1 = (2, 6, 6)$, $\tau_2 = (2, 9, 9)$, $\tau_3 = (3, 12, 12)$. Task τ_1 has priority $p_1 = 3$ (highest), task τ_2 has priority $p_2 = 2$, task τ_3 has priority $p_3 = 1$ (lowest)

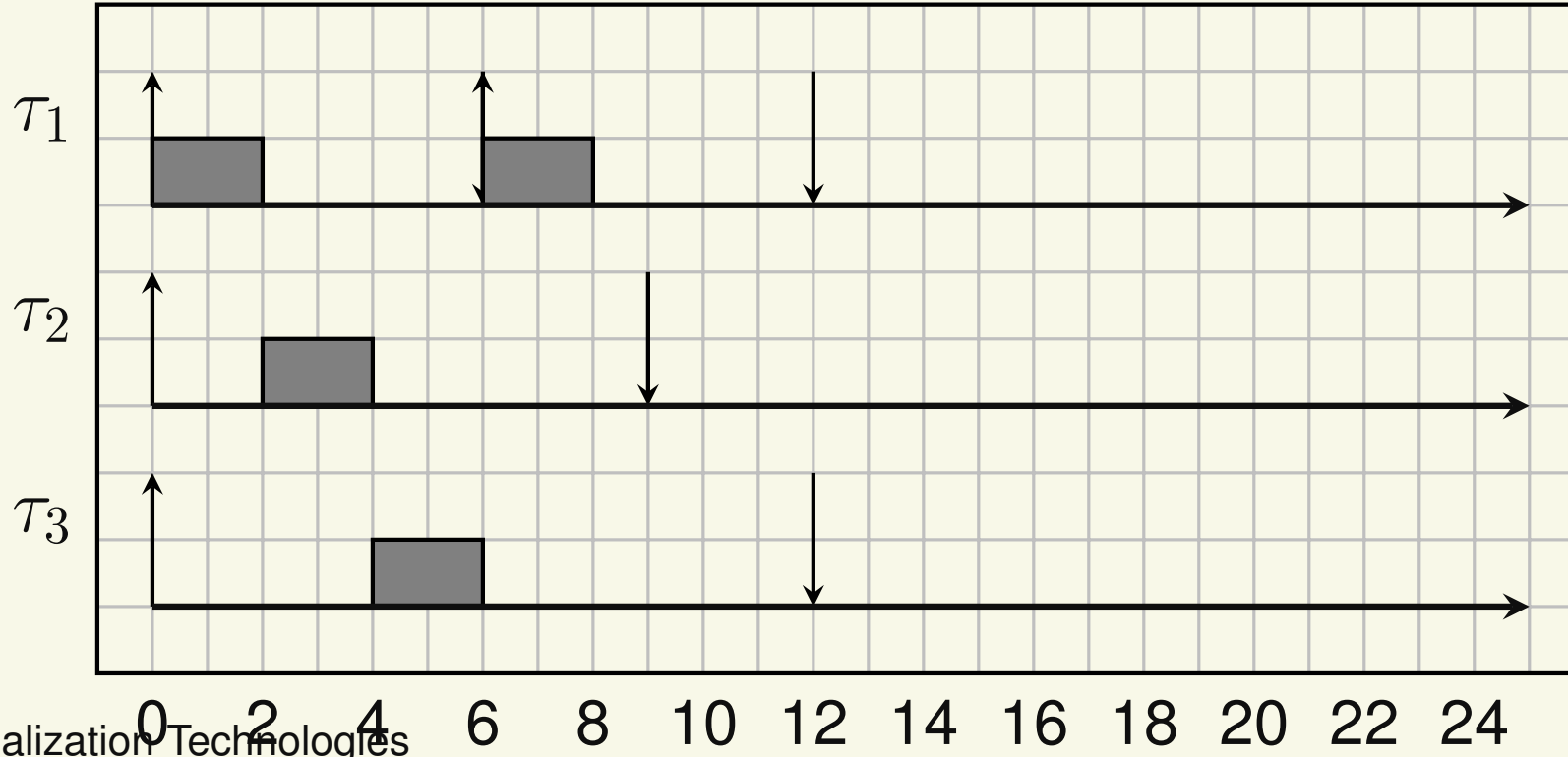

Example of Schedule

- Consider the following task set: $\tau_1 = (2, 6, 6)$, $\tau_2 = (2, 9, 9)$, $\tau_3 = (3, 12, 12)$. Task τ_1 has priority $p_1 = 3$ (highest), task τ_2 has priority $p_2 = 2$, task τ_3 has priority $p_3 = 1$ (lowest)

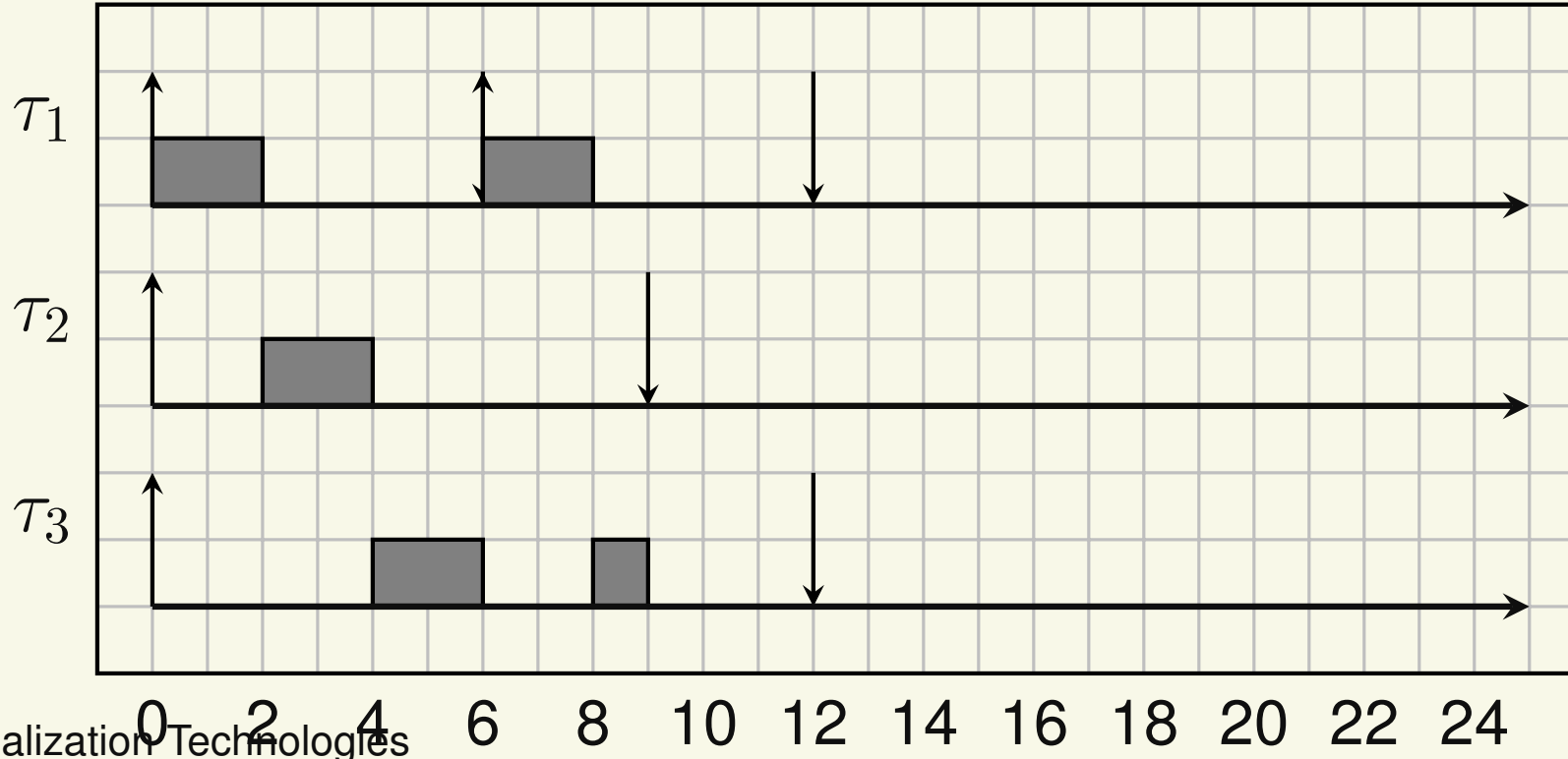

Example of Schedule

- Consider the following task set: $\tau_1 = (2, 6, 6)$, $\tau_2 = (2, 9, 9)$, $\tau_3 = (3, 12, 12)$. Task τ_1 has priority $p_1 = 3$ (highest), task τ_2 has priority $p_2 = 2$, task τ_3 has priority $p_3 = 1$ (lowest)

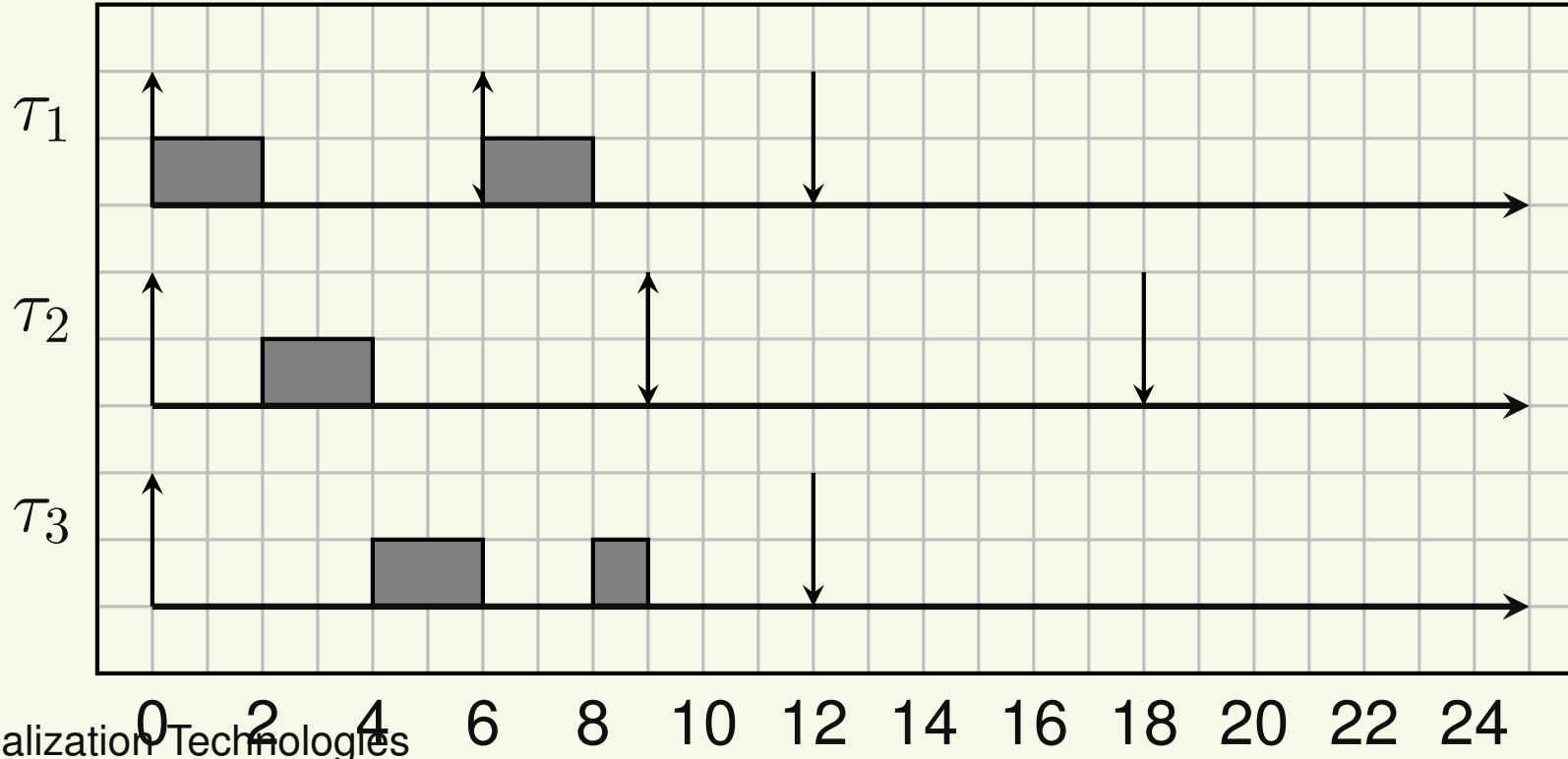

Example of Schedule

- Consider the following task set: $\tau_1 = (2, 6, 6)$, $\tau_2 = (2, 9, 9)$, $\tau_3 = (3, 12, 12)$. Task τ_1 has priority $p_1 = 3$ (highest), task τ_2 has priority $p_2 = 2$, task τ_3 has priority $p_3 = 1$ (lowest)

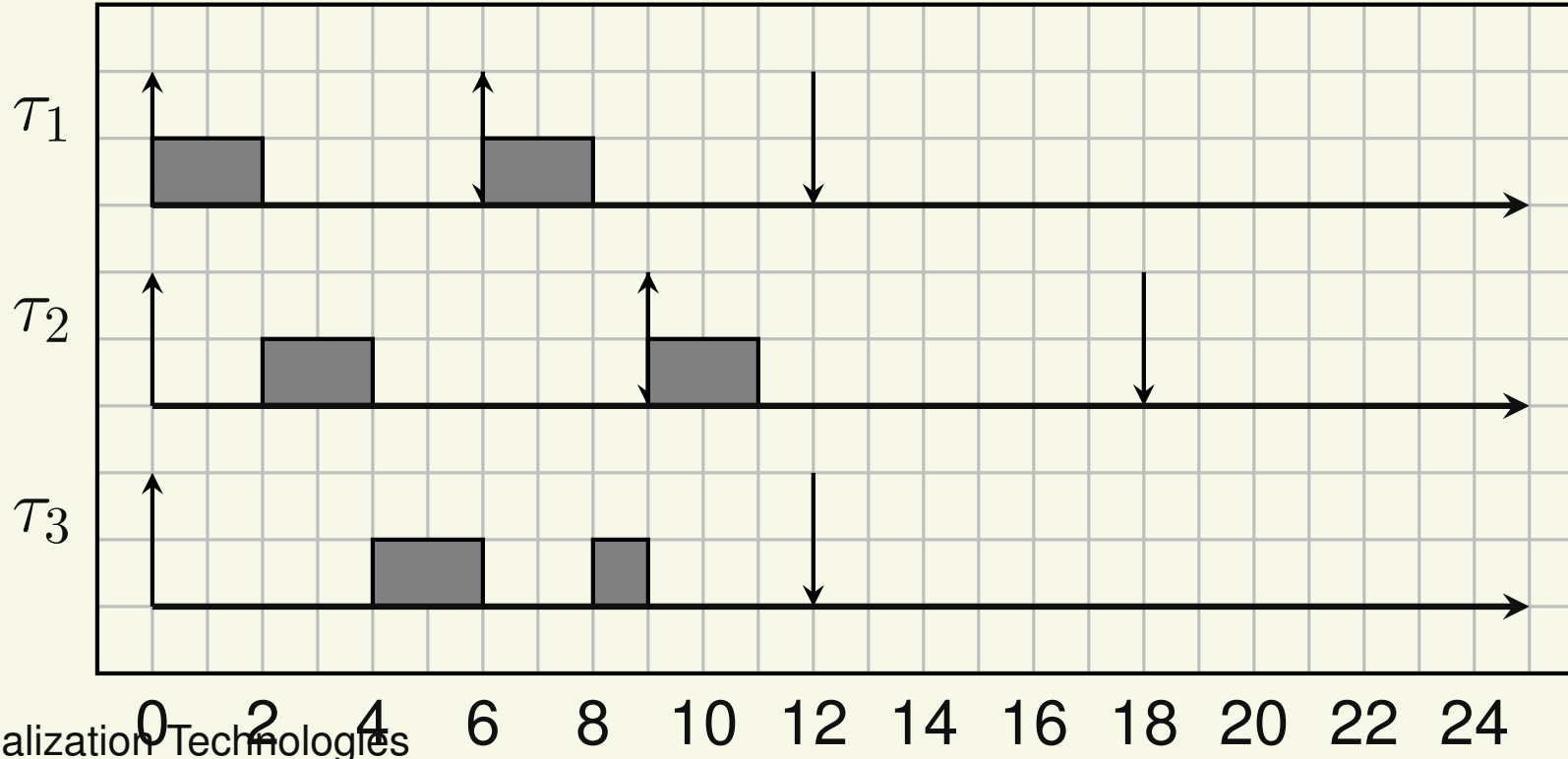

Example of Schedule

- Consider the following task set: $\tau_1 = (2, 6, 6)$, $\tau_2 = (2, 9, 9)$, $\tau_3 = (3, 12, 12)$. Task τ_1 has priority $p_1 = 3$ (highest), task τ_2 has priority $p_2 = 2$, task τ_3 has priority $p_3 = 1$ (lowest)

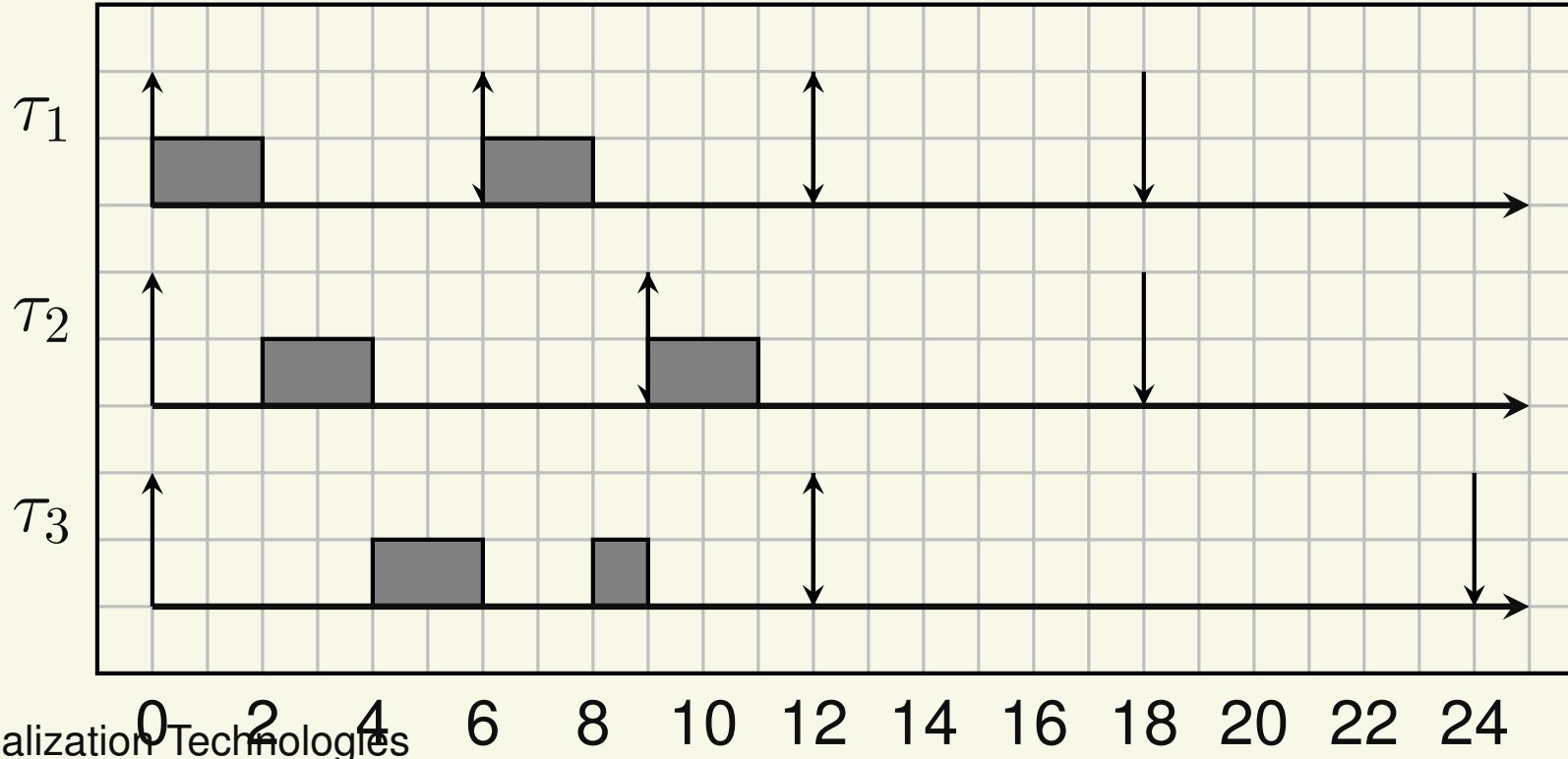

Example of Schedule

- Consider the following task set: $\tau_1 = (2, 6, 6)$, $\tau_2 = (2, 9, 9)$, $\tau_3 = (3, 12, 12)$. Task τ_1 has priority $p_1 = 3$ (highest), task τ_2 has priority $p_2 = 2$, task τ_3 has priority $p_3 = 1$ (lowest)

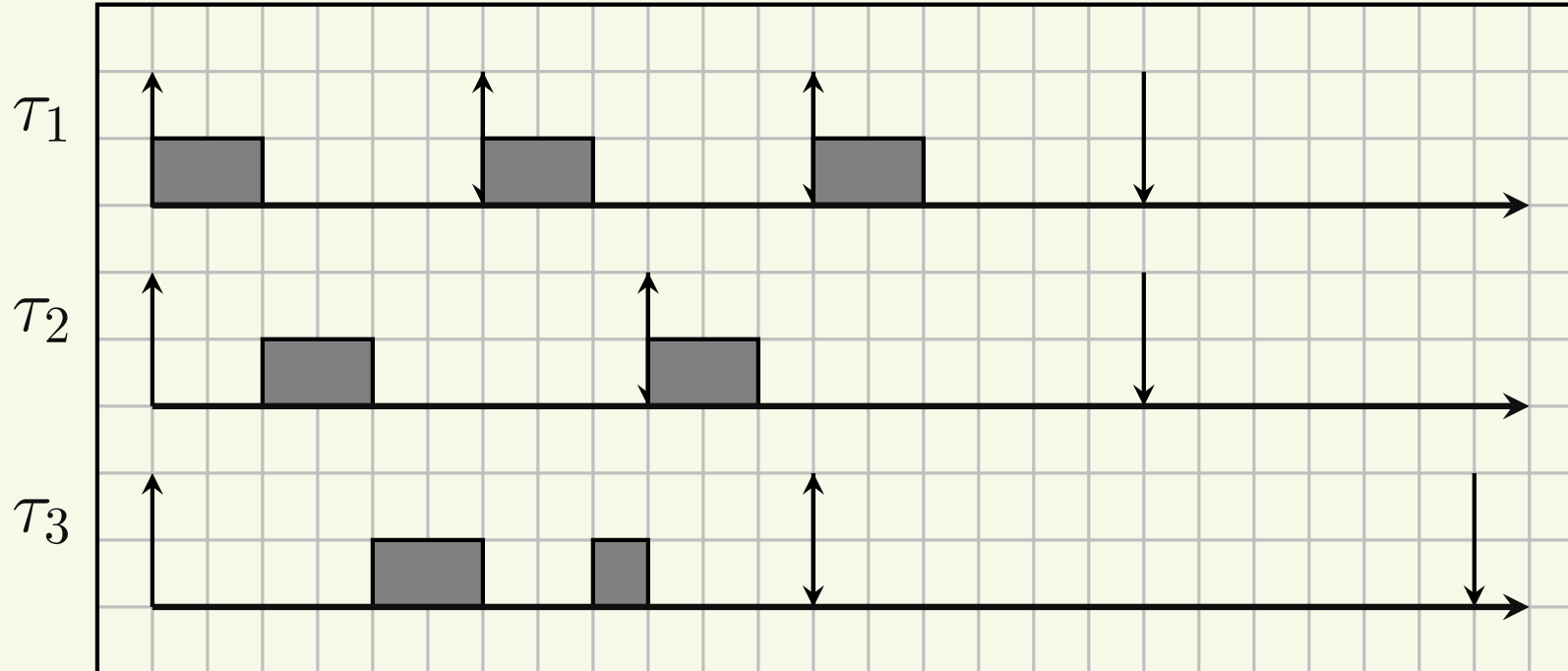

Example of Schedule

- Consider the following task set: $\tau_1 = (2, 6, 6)$, $\tau_2 = (2, 9, 9)$, $\tau_3 = (3, 12, 12)$. Task τ_1 has priority $p_1 = 3$ (highest), task τ_2 has priority $p_2 = 2$, task τ_3 has priority $p_3 = 1$ (lowest)

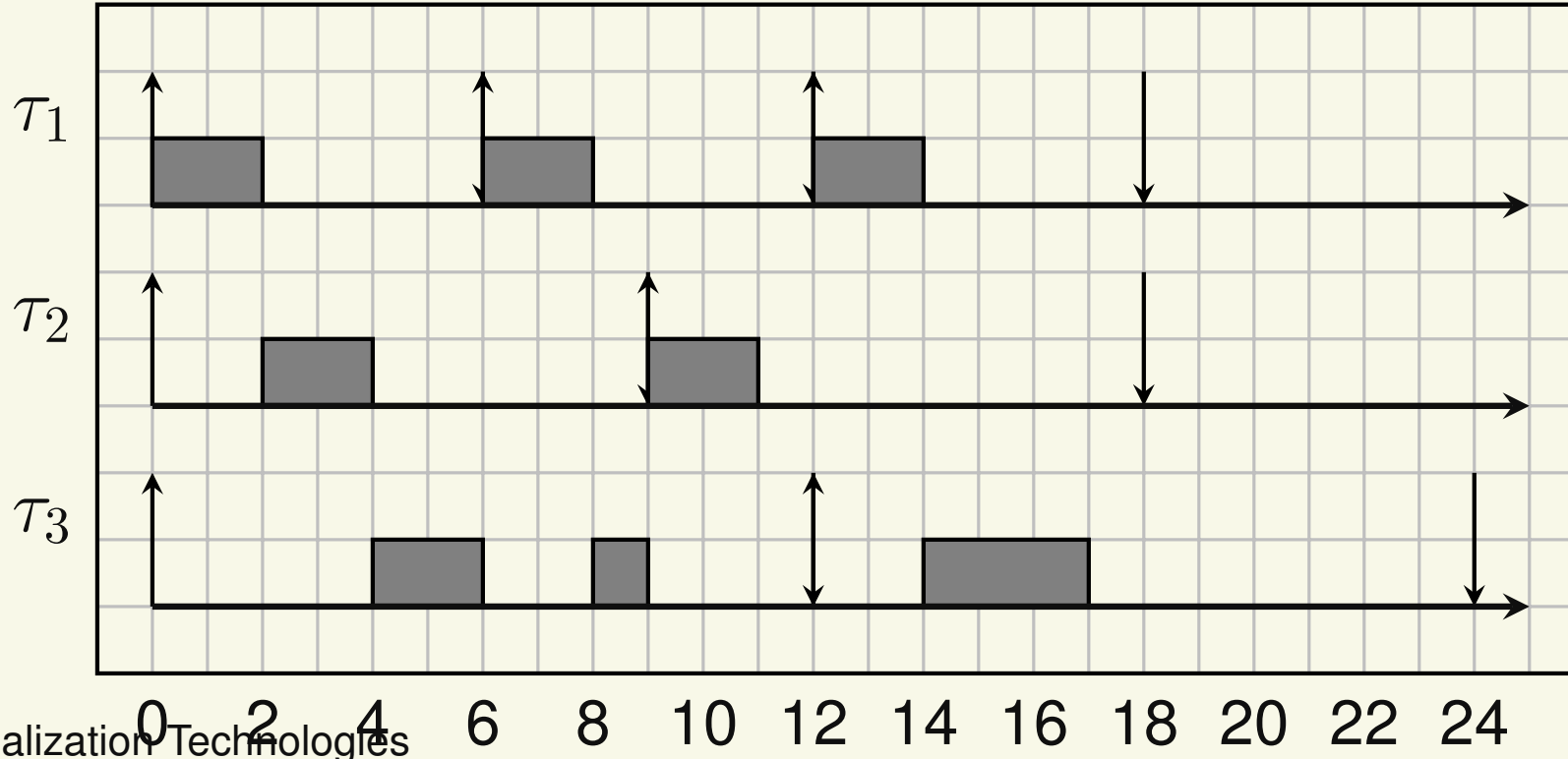

Example of Schedule

- Consider the following task set: $\tau_1 = (2, 6, 6)$, $\tau_2 = (2, 9, 9)$, $\tau_3 = (3, 12, 12)$. Task τ_1 has priority $p_1 = 3$ (highest), task τ_2 has priority $p_2 = 2$, task τ_3 has priority $p_3 = 1$ (lowest)

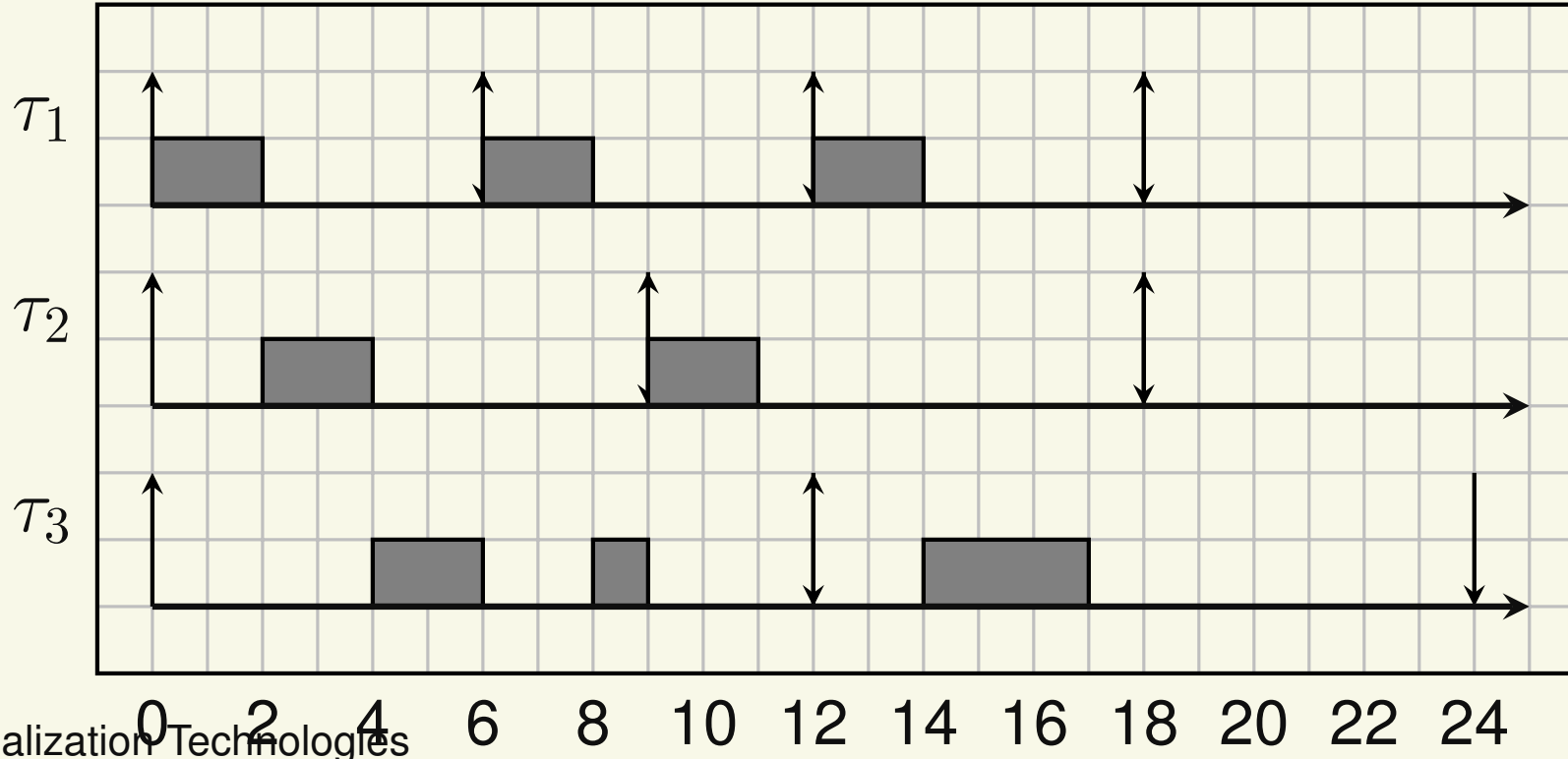

Example of Schedule

- Consider the following task set: $\tau_1 = (2, 6, 6)$, $\tau_2 = (2, 9, 9)$, $\tau_3 = (3, 12, 12)$. Task τ_1 has priority $p_1 = 3$ (highest), task τ_2 has priority $p_2 = 2$, task τ_3 has priority $p_3 = 1$ (lowest)

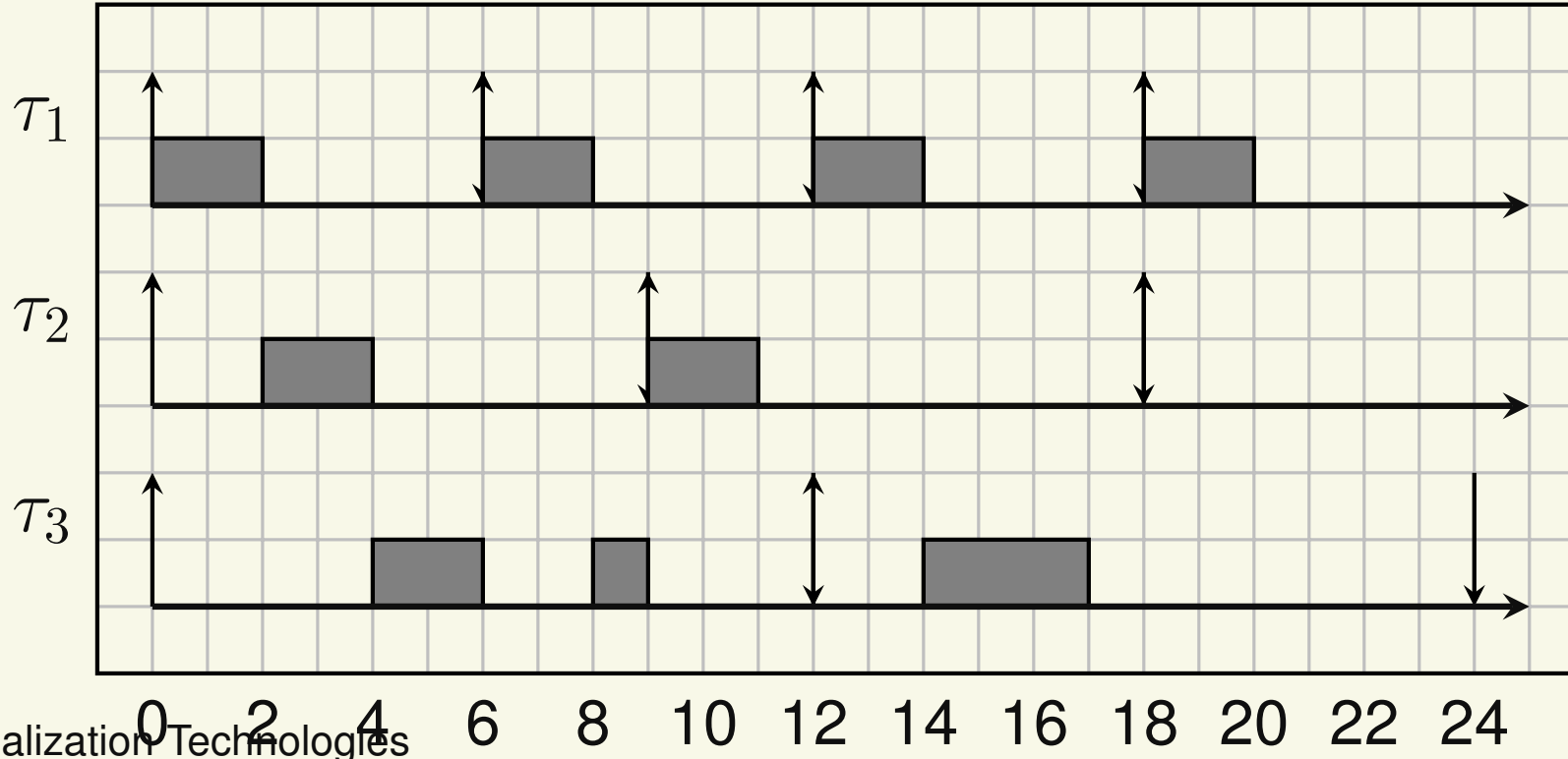

Example of Schedule

- Consider the following task set: $\tau_1 = (2, 6, 6)$, $\tau_2 = (2, 9, 9)$, $\tau_3 = (3, 12, 12)$. Task τ_1 has priority $p_1 = 3$ (highest), task τ_2 has priority $p_2 = 2$, task τ_3 has priority $p_3 = 1$ (lowest)

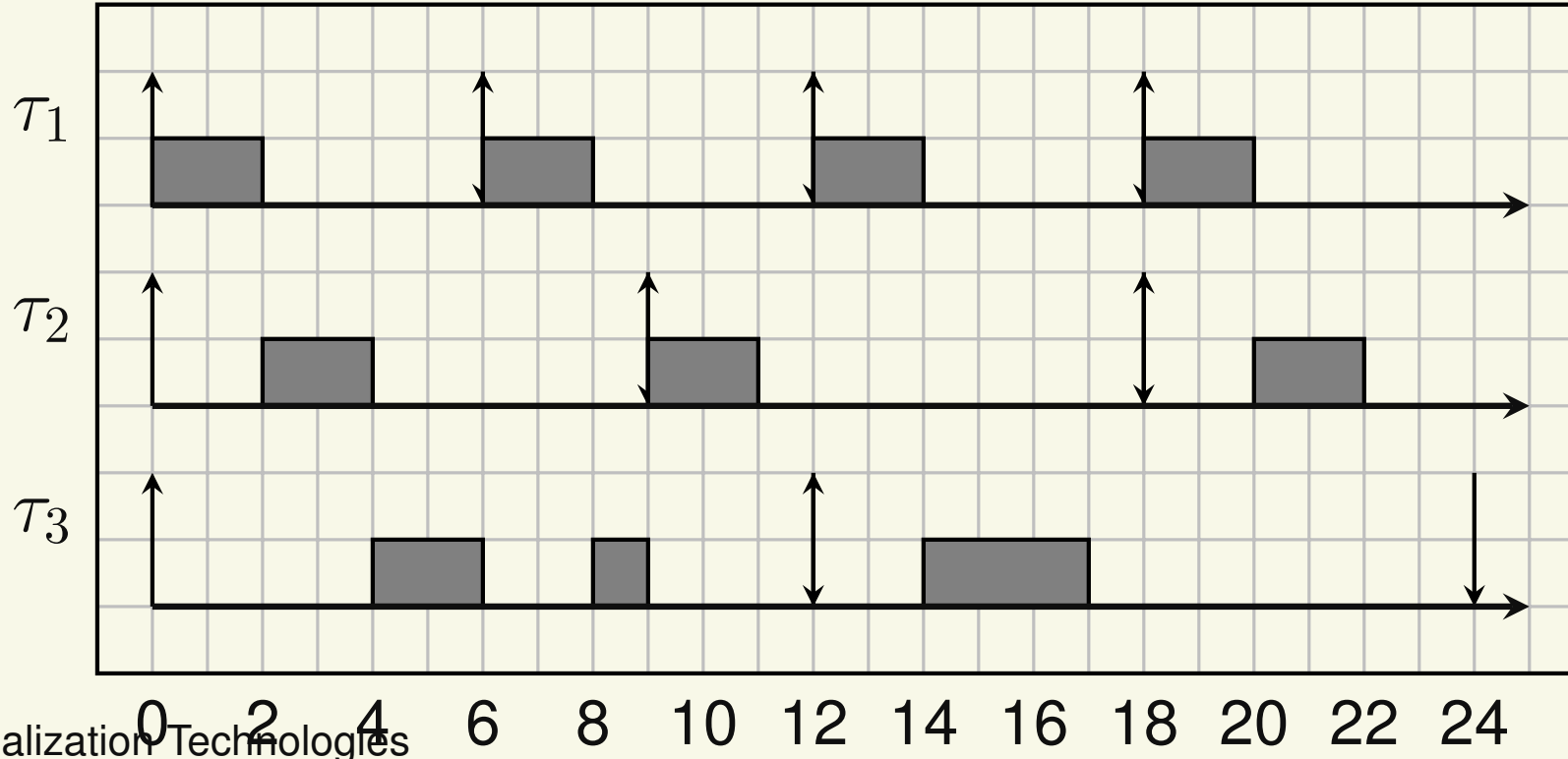

Another Example (non-schedulable)

- Consider the following task set: $\tau_1 = (3, 6, 6)$, $p_1 = 3$, $\tau_2 = (2, 4, 8)$, $p_2 = 2$, $\tau_3 = (2, 12, 12)$, $p_3 = 1$

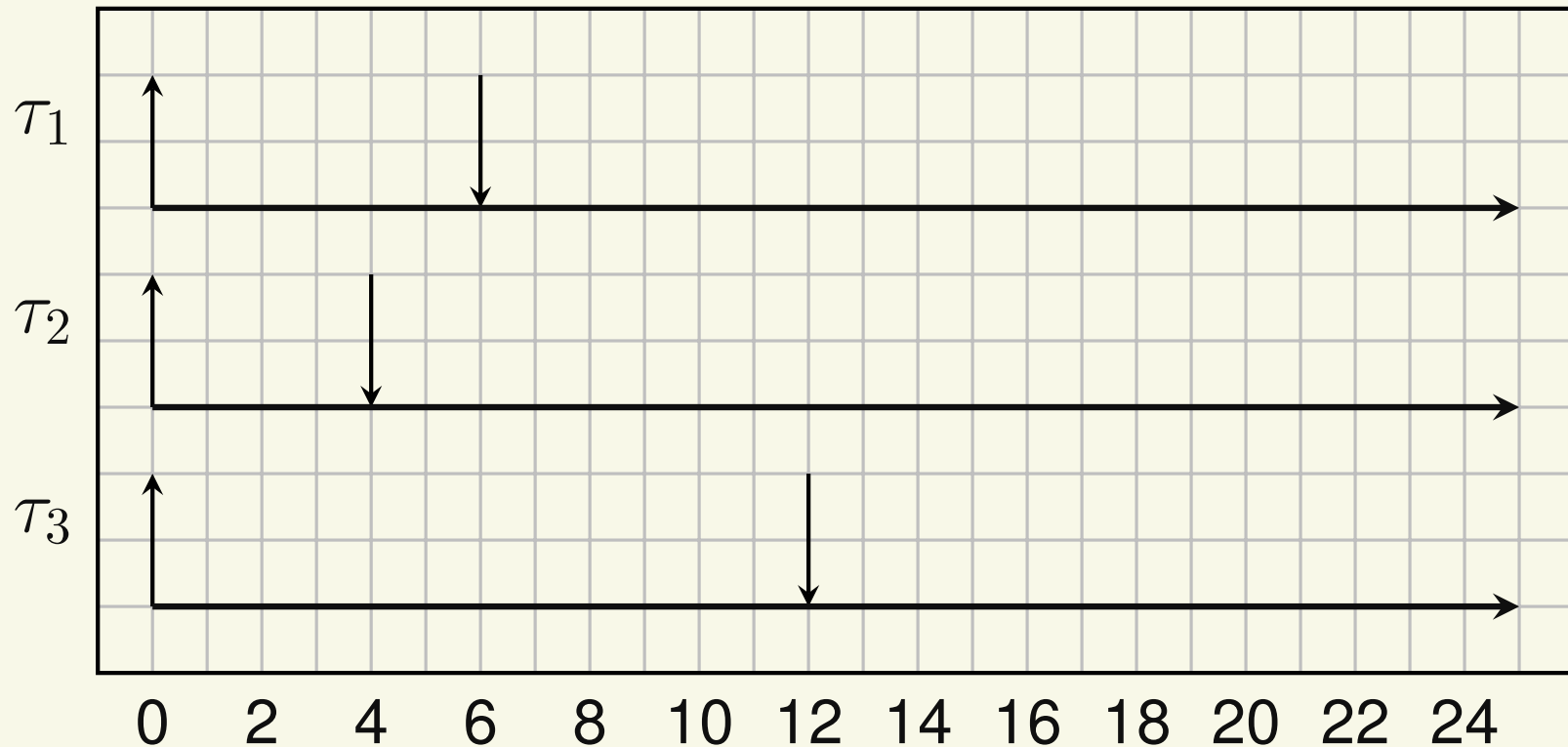

In this case, task τ_2 misses its deadline!

Another Example (non-schedulable)

- Consider the following task set: $\tau_1 = (3, 6, 6)$, $p_1 = 3$, $\tau_2 = (2, 4, 8)$, $p_2 = 2$, $\tau_3 = (2, 12, 12)$, $p_3 = 1$

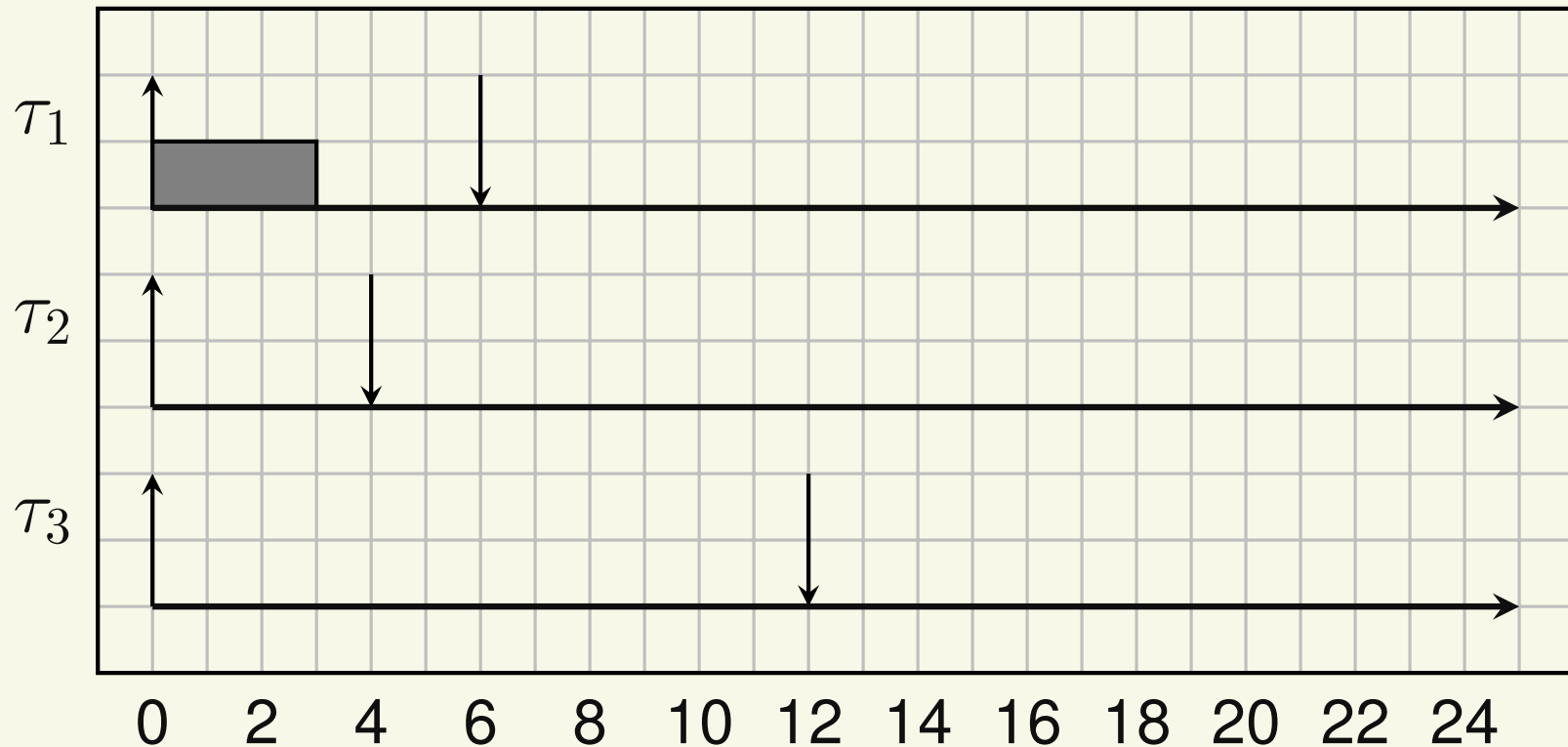

Virtualization Technologies
In this case, task τ_2 misses its deadline!

Another Example (non-schedulable)

- Consider the following task set: $\tau_1 = (3, 6, 6)$, $p_1 = 3$, $\tau_2 = (2, 4, 8)$, $p_2 = 2$, $\tau_3 = (2, 12, 12)$, $p_3 = 1$

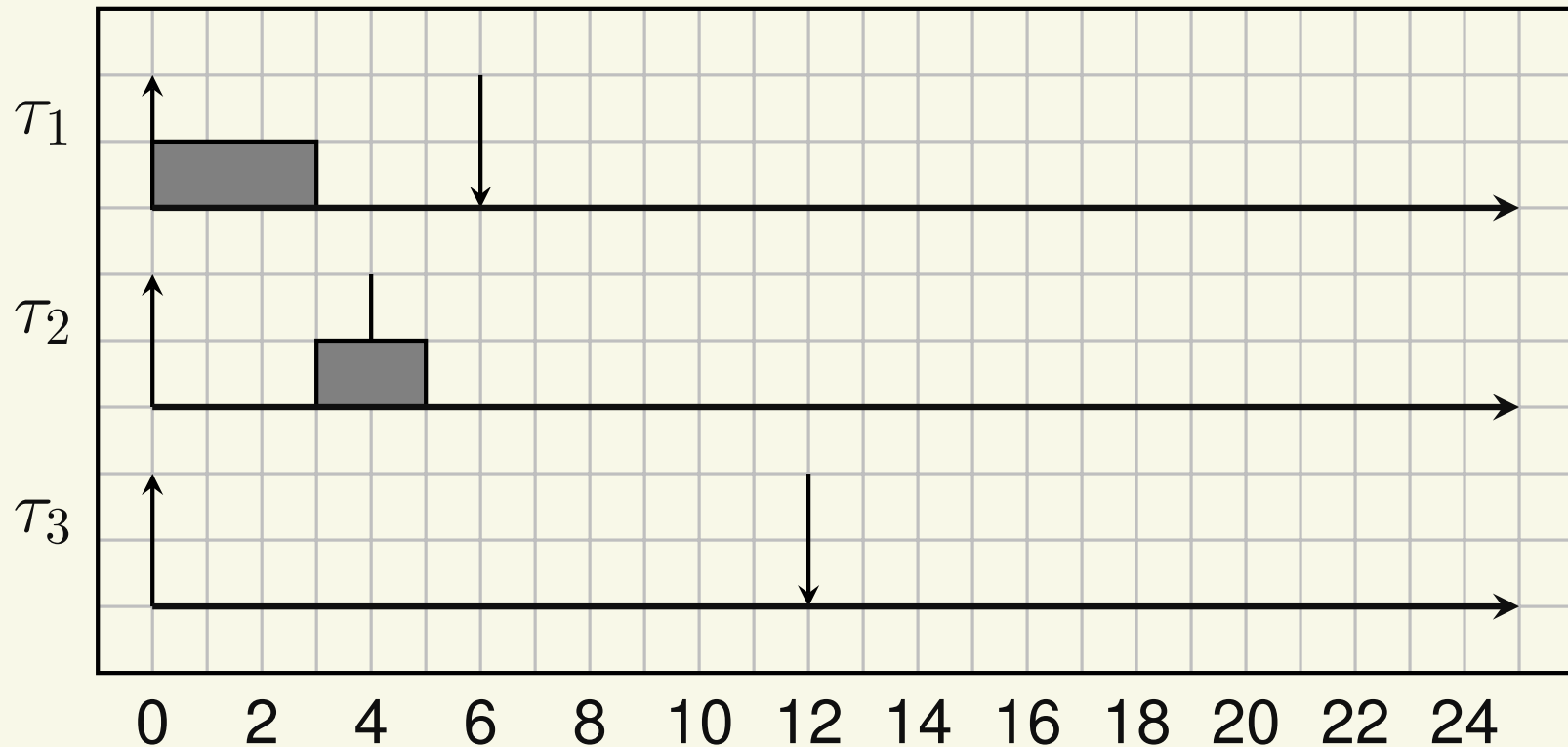

In this case, task τ_2 misses its deadline!

Notes about Priority Scheduling

- Some considerations about the schedule shown before:
 - The response time of the task with the highest priority is minimum and equal to its WCET
 - The response time of the other tasks depends on the *interference* of the higher priority tasks
 - The priority assignment may influence the schedulability of a task set
 - Problem: how to assign tasks' priorities so that a task set is schedulable?

What About Multiple Cores?

- How to schedule tasks on multiple CPUs / cores?
 - First idea: partitioned scheduling
- Statically assign tasks to CPU cores
- Reduce the problem of scheduling on M cores to M instances of uniprocessor scheduling

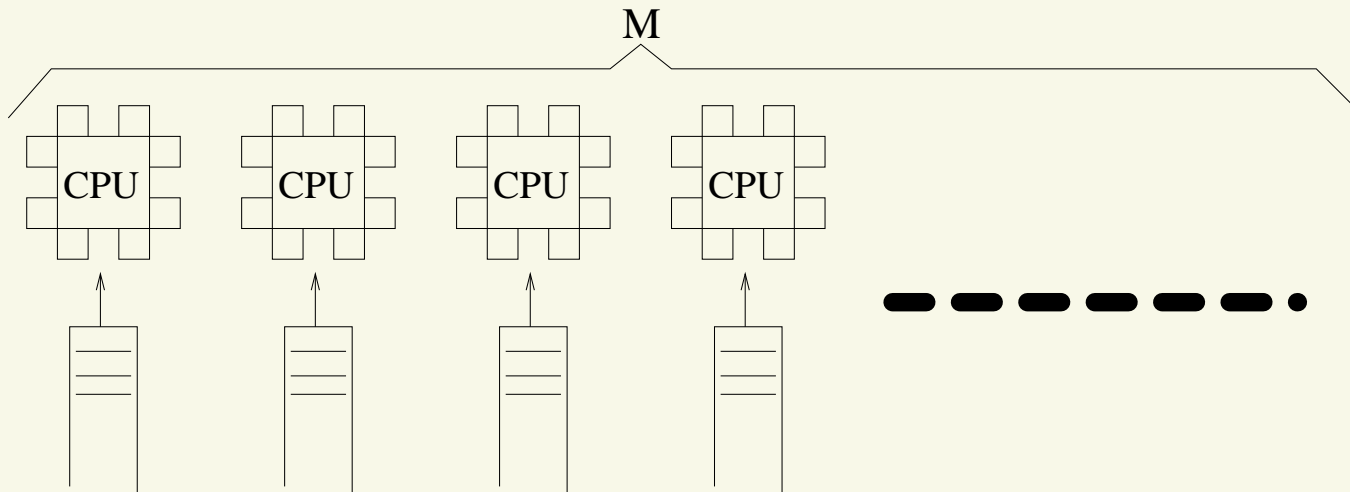

Or...

- One single task queue, shared by M CPU cores
 - The first M ready tasks are selected
 - What happens using fixed priorities?
 - Tasks are not bound to specific CPUs
 - Tasks can often migrate between different CPUs
- Problem: UP schedulers do not work well!

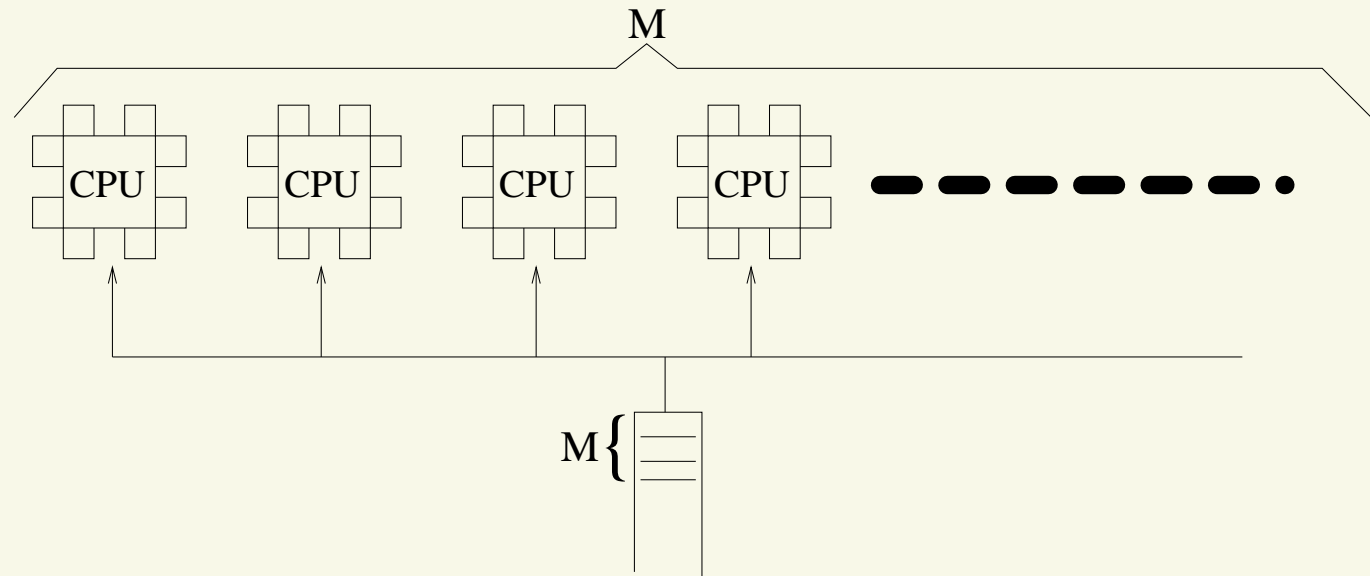

Using Fixed Priorities in Linux

- `SCHED_FIFO` and `SCHED_RR` use fixed priorities
 - They can be used for real-time tasks, to implement RM and DM
 - Real-time tasks have priority over non real-time (`SCHED_OTHER`) tasks
- The difference between the two policies is visible when more tasks have the same priority
 - In real-time applications, try to avoid multiple tasks with the same priority

Setting the Scheduling Policy

```
int sched_get_priority_max(int policy);
int sched_get_priority_min(int policy);

int sched_setscheduler(pid_t pid, int policy,
                      const struct sched_param *param);
int sched_setparam(pid_t pid,
                  const struct sched_param *param);
```

- If `pid == 0`, then the parameters of the running task are changed
- The only meaningful field of `struct sched_param` is `sched_priority`

Problems with Real-Time Priorities

- In general, “regular” (SCHED_OTHER) tasks are scheduled in background respect to real-time ones
- Real-time tasks can / starve other applications
- Example: the following task scheduled at high priority can make a CPU / core unusable

```
void bad_bad_task()  
{  
    while(1);  
}
```

- Real-time computation have to be limited (use real-time priorities only when **really needed!**)
- Using real-time priorities requires root privileges (or part of them!)

Real-Time Throttling

- A “bad” rt task can make a CPU / core unusable...
- ...Linux provides the *real-time throttling* mechanism
 - How does real-time throttling interfere with real-time guarantees?
 - Given a priority assignment, a taskset is guaranteed all the deadlines if no throttling mechanism is used...
 - ...But, what happens in case of throttling?
- Very useful idea, but something more “theoretically founded” might be needed...

What About EDF?

- Can EDF (or similar) be supported in Linux?
- Problem: the kernel is not aware of tasks deadlines...
- ...But deadlines are needed to schedule the tasks
 - EDF schedules tasks based on absolute deadlines
- So, a **more advanced API** is needed...

EDF on a real OS

- More advanced API:
 - Assign relative deadlines D_i to the tasks...
 - A *runtime* and a *period* are also needed
- Moreover, $d_{i,j} = r_{i,j} + D_i$...
 - ...However, how can the scheduler know $r_{i,j}$?
 - The scheduler is not aware of jobs...
- To use EDF, the scheduler must know when a job starts / finishes
 - Modify applications, or guess...

Tasks and Jobs... And Scheduling Deadlines!

- **Applications must be modified** to signal the beginning / end of a job (some kind of `startjob()` / `endjob()` system call)...
- ...Or the scheduler can assume that **a new job arrives each time a task wakes up!**
- Alternative: assign dynamic *scheduling deadlines*
 - Scheduling deadline d_i^s : **assigned by the kernel**
 - If the scheduling deadline d_i^s matches the absolute deadline $d_{i,j}$ of a job, then the scheduler can respect $d_{i,j}$!!!

Real-Time in VMs???

- Running real-time applications on an RTOS is not a problem...
- ...But, can real-time applications run in virtual machines?
 - Real-Time in Virtual Machines???
 - But... Why?
- Component-Based Development
 - Complex applications: sets of smaller components
 - Both functional and temporal interfaces
- Security (isolate real-time applications in a VM)
- Easy deployment; Time-sensitive clouds

Real-Time in VMs

- Real-Time applications running in a VM?
 - As for OSs, two different aspects

Real-Time in VMs

- Real-Time applications running in a VM?
 - As for OSs, two different aspects
 - Resource allocation/management (scheduling)
 - CPU allocation/scheduling: lot of work in literature

Real-Time in VMs

- Real-Time applications running in a VM?
 - As for OSs, two different aspects
 - Latency (host and guest)
 - Latencies not investigated too much (yet!)

Real-Time in VMs

- Real-Time applications running in a VM?
 - As for OSs, two different aspects
 - Resource allocation/management (scheduling)
 - Latency (host and guest)
 - CPU allocation/scheduling: lot of work in literature
 - Latencies not investigated too much (yet!)
- Virtualization: full hw or OS-level
 - OS-Level virtualization: real-time performance of the host kernel
 - Hw virtualization: hypervisors (example: KVM or Xen) can introduce latencies!

Latency

- Latency: measure of the difference between the **theoretical** and **actual** schedule
 - Task τ **expects** to be scheduled at time t ...
 - ... but **is actually scheduled** at time t'
 - \Rightarrow Latency $L = t' - t$
- The latency L can be accounted for in schedulability analysis
 - Similar to what is done for shared resources, etc...
 - Strange “shared resource”: the OS kernel (or the hypervisor)

Example: Periodic Task

- Consider a periodic task

```
/* ... */  
while(1) {  
    /* Job body */  
    clock_nanosleep(CLOCK_REALTIME,  
                    TIMER_ABSTIME, &r, NULL);  
    timespec_add_us(&r, period);  
}
```

- The task expects to be executed at time r
($= r_0 + jT$)...
- ...But is **sometimes delayed to $r_0 + jT + \delta$**

Theoretical Schedule

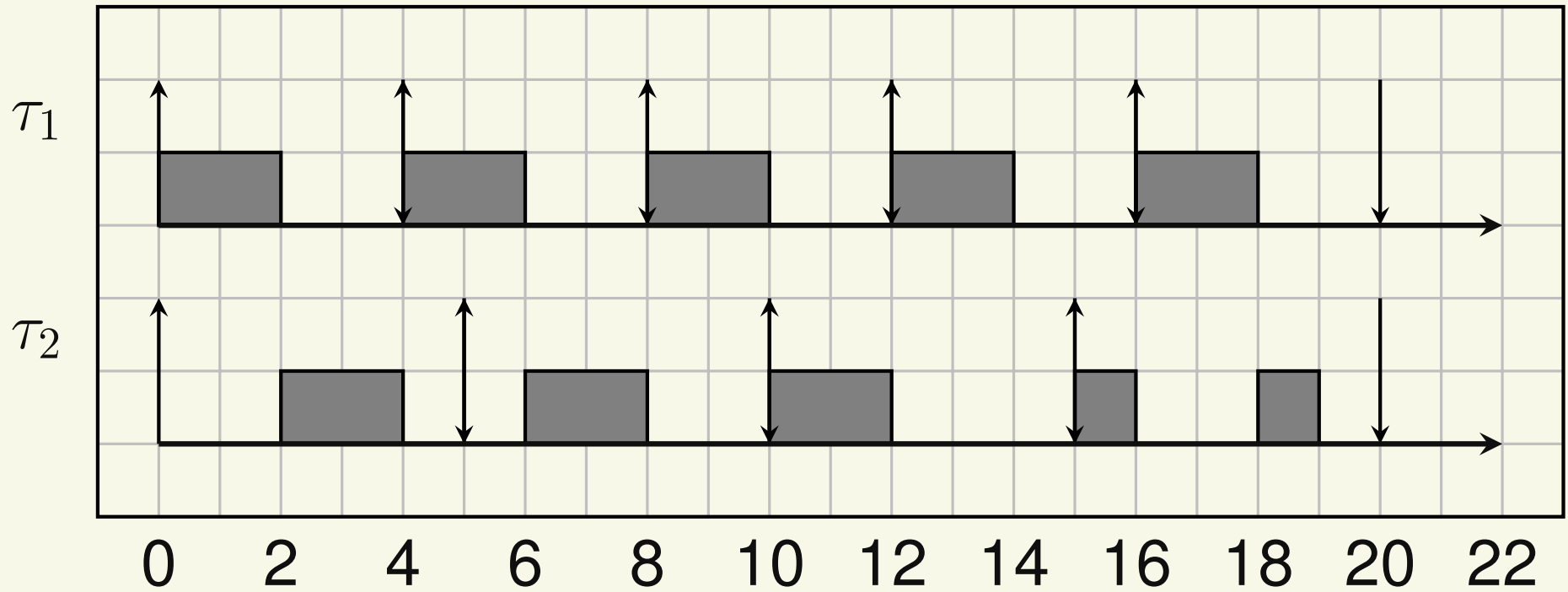

Actual Schedule

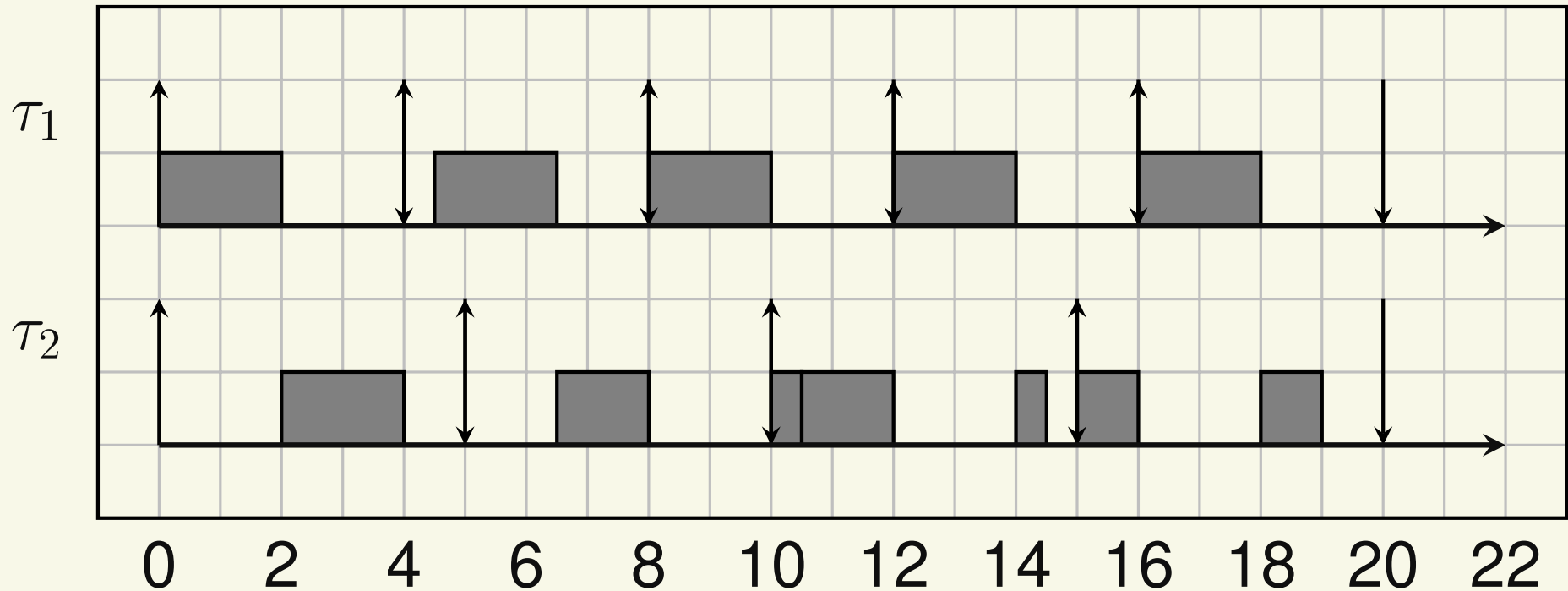

- What happens if the 2^{nd} job of τ_1 arrives a little bit later???
- The 2^{nd} job of τ_2 misses a deadline!!!

Effects of the Latency

- Upper bound for L ? If not known, no schedulability analysis!!!
 - The latency must be *bounded*: $\exists L^{max} : L < L^{max}$
- If L^{max} is too high, only few task sets result to be schedulable
 - The worst-case latency L^{max} cannot be too high

Sources of Latency — 1

- Task: stream of jobs (activations) arriving at time r_j
- Task scheduled at time $t' > r_j \rightarrow$ Delay $t' - r_j$ caused by:
 1. Job arrival (task activation) signaled at time $r_j + L^1$
 2. Event served at time $r_j + L^1 + L^2$
 3. Task actually scheduled at $r_{i,j} + L^1 + L^2 + I$

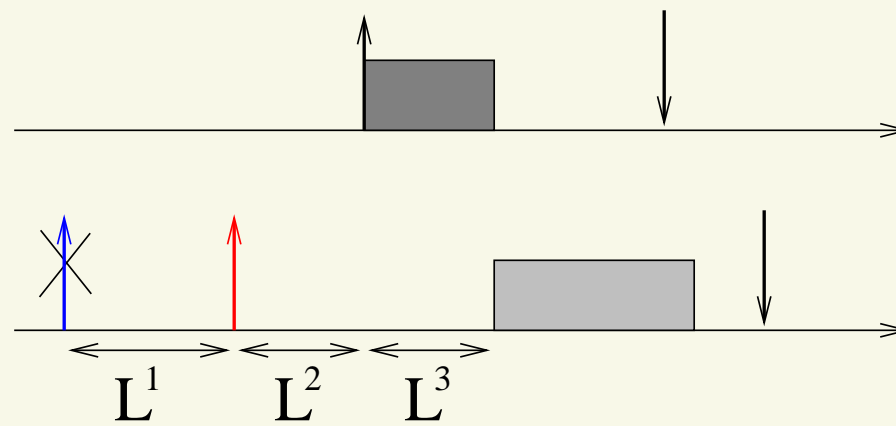

Sources of Latency — 2

- $L = L^1 + L^2 + I$
- I : interference from higher priority tasks
 - Not really a latency!!!
- L^2 : *non-preemptable section latency* L^{np}
 - Due to non-preemptable sections in the kernel (or hypervisor!) or to deferred interrupt processing
- L^1 : delayed interrupt generation
 - Generally small
 - Hardware (or virtualized) timer interrupt: *timer resolution latency* L^{timer}

Latency in Linux

- Tool (`cyclictest`) to measure the latency
 - Periodic task scheduled at the highest priority
 - Response time equal to execution time (almost 0)
- Vanilla kernel: depends on the configuration
 - Can be tens of milliseconds
- Preempt-RT patchset
(<https://wiki.linuxfoundation.org/realtime>):
reduce latency to less than 100 microseconds
 - Tens of microseconds on well-tuned systems!
- So, **real-time on Linux is not an issue**
 - **Is this valid for hypervisors/VMs too?**

What About VM Latencies?

- Hypervisor: software component responsible for executing multiple OSs on the same physical node
 - **Can introduce latencies** too!
- Different kinds of hypervisors:
 - Xen: bare-metal hypervisor (*below* the Linux kernel)
 - Common idea: the hypervisor is small/simple, so it causes small latencies
 - KVM: hosted hypervisor (Linux kernel module)
 - Latencies reduced by using Preempt-RT
 - Linux developers already did lot of work!!!

Hypervisor Latency

- Same strategy/tools used for measuring kernel latency
- Idea: run `cyclictest` in a VM
 - `cyclictest` process ran in the guest OS...
 - ...instead of host OS
- `cyclictest` period: $50\mu s$
- “Kernel stress” to trigger high latencies
 - Non-real-time processes performing lot of syscalls or triggering lots of interrupts
 - Executed in the host OS (for KVM) or in Dom0 (for Xen)
- Experiments on multiple x86-based systems

Hypervisor Latencies

Intel Core Duo

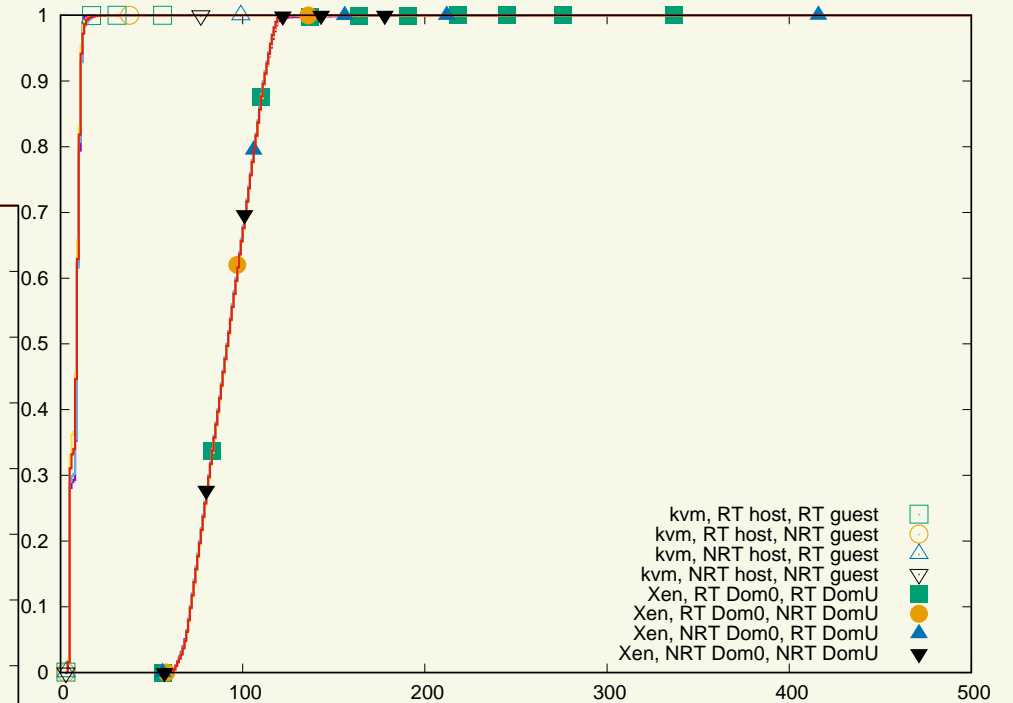
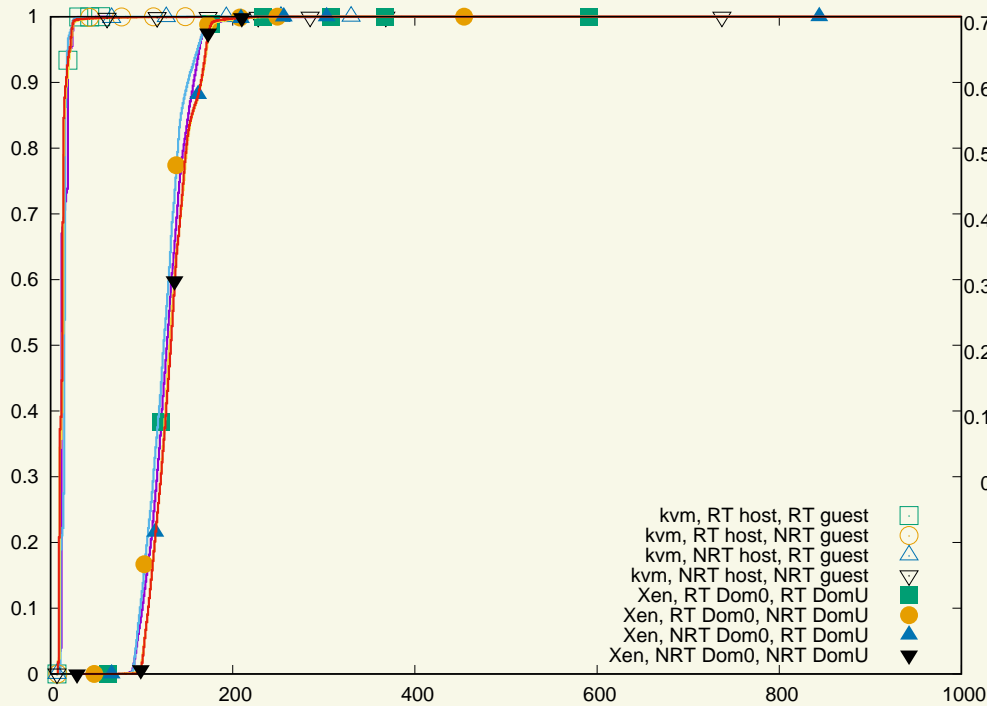

Intel Core i7

Worst Cases

Kernels	Core Duo		Core i7	
	Xen	KVM	Xen	KVM
NRT/NRT	3216 μs	851 μs	785 μs	275 μs
NRT/RT	4152 μs	463 μs	1589 μs	243 μs
RT/NRT	3232 μs	233 μs	791 μs	99 μs
RT/RT	3956 μs	71 μs	1541 μs	72 μs

- Preempt-RT helps a lot with KVM
 - Good worst-case values (less than 100 μs)
- Preempt-RT in the guest is dangerous for Xen
 - Worst-case values stay high

Hypervisor vs Kernel

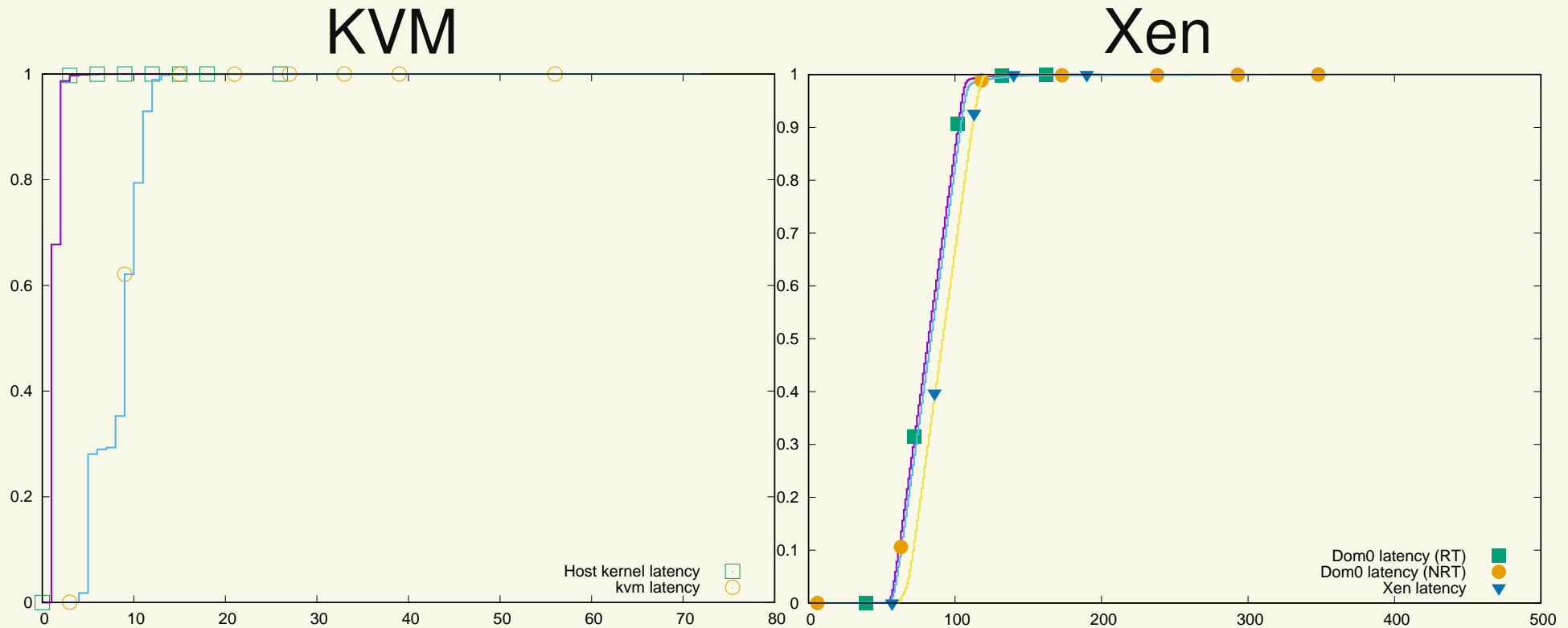

- **Worst Cases:**

- Host: $29\mu s$
- Dom0: $201\mu s$ with Preempt-RT, $630\mu s$ with NRT

Investigating Xen Latencies

- KVM: usable for real-time workloads
- Xen: strange results
 - Larger latencies in general
 - Using Preempt-RT in the guest increases the latencies?
- Xen latencies are not due to the hypervisor's scheduler
 - Repeating the experiments with the null scheduler did not decrease the experienced latencies

Impact of the Kernel Stress

- Experiments repeated without “Kernel Stress” on Dom0
 - This time, using Preempt-RT in the guest reduces latencies!
 - Strange result: Dom0 load *should not* affect the guest latencies...

Kernels	Core Duo		Core i7	
	Stress	No Stress	Stress	No Stress
NRT/NRT	3216 μs	3179 μs	785 μs	1607 μs
NRT/RT	4152 μs	1083 μs	1589 μs	787 μs
RT/NRT	3232 μs	3359 μs	791 μs	1523 μs
RT/RT	3956 μs	960 μs	1541 μs	795 μs

Virtualization Mechanisms

- Xen virtualization: PV, HVM, PVH, ...
 - PV: everything is para-virtualized
 - HVM: full hardware emulation (through qemu) for devices (some para-virtualized devices, too); use CPU virtualization extensions (Intel VT-x, etc...)
 - PVH: hardware virtualization for the CPU + para-virtualized devices (trade-off between the two)
- Dom0 kernel does not affect results; focus on guest kernel

Guest Kernel	PV	PVH	HVM
NRT	$661\mu s$	$1276\mu s$	$1187\mu s$
RT	$178\mu s$	$216\mu s$	$4470\mu s$

What's up with HVM?

- HVM uses qemu as *Device Model* (DM)
 - Qemu instance running in Dom0
 - Used for boot and emulating some devices...
 - ...But somehow involved in the strange latencies!!!
- Scheduling all qemu threads with priority 99, the worst-case latencies are comparable with PV / PVH!!!
 - High HVM latencies due to the Kernel Stress workload preempting qemu...
- Summing up: **for good real-time performance, use PV or PVH!**

Cyclictest Period

- Most of the latencies larger than cyclictest period...
- Are hypervisor's timers able to respect that period?
 - Example of timer resolution latency...
- So, let's try a larger period!
 - $500\mu s$ and $1ms$ instead of $50\mu s$
 - Measure timer resolution latency → no kernel stress
- Results are much better!
 - $P = 500\mu s$: worst-case latency $112\mu s$ (HVM), $82\mu s$ (PVH) or $101\mu s$ (PV)
 - $P = 1000\mu s$: worst-case latency $129\mu s$ (HVM), $124\mu s$ (PVH) or $113\mu s$ (PV)

Further Analysis

- Xen latencies seem to be mainly due to timer resolution latency
 - Turned out to be an issue in the Linux code handling Xen's para-virtualized timers
 - Linux jargon: “clockevent device”
 - Does not activate a timer at less than $100\mu s$ from current time (`TIMER_SLOP`)
- After reducing the timer slop, average latency smaller than $50\mu s$ even for `cyclictst` with period $50\mu s$
 - Still larger than KVM latencies (probably due to non-preemptable sections?)

Final Results

- Xen with a properly configured `TIMER_SLOP`:
 - Timer resolution latency reduced to almost 0
 - Non-preemptable section latency dependent on the virtualization technology
 - Worst-case latencies highly dependent on the hardware
 - Example: some old CPUs need to (trap and) emulate `rdtsc` $\Rightarrow 15\mu s$ additional latency
- Xeon CPU: $28\mu s$ with PVH, $72\mu s$ for PV (KVM is $44\mu s$)
- Core 2 CPU: $88\mu s$ for PV, $182\mu s$ for PVH (KVM is $71\mu s$)

Reproducible Results

- Results can be reproduced on your test machine
 - You just need some manual installation of KVM, Xen, etc...

`http://retis.santannapisa.it/luca/VMLatencies`

- Scripts to reproduce the previous experiments
 - Numbers depend on the hw, but the obtained figures are consistent with the previous results
- Other figures can be easily obtained by modifying scripts / configuration files

Summing Up

- Latencies experienced in a VM (`cyclictest`)
 - **KVM**: Preempt-RT allows to achieve low latencies → **usable for real-time**
 - **Xen**: **high latencies**, **Preempt-RT does not help**, strange impact of the Dom0 load
- **Xen behaves better when PV or PVH is used**
 - Part of the latencies due to the DM (qemu running in Dom0)?
- Xen experiences a large timer resolution latency
 - **Fixable by modifying the guest kernel**

Latencies and Scheduling

- Most of the industrial work on real-time virtualization **focused on latency reduction**
 - Example: real-time KVM industrial solution based on vCPU pinning — No scheduling!!!
- Scheduling VMs is still needed to share hardware resources...
 - Bounded latencies are needed to have precise and accurate vCPU scheduling...
 - ...But **appropriate scheduling algorithms are still needed!!!**
- Advanced scheduling algorithms are useless if latencies are not bounded, and bounded latencies are useless if appropriate scheduling is not used!

Combining Real-Time Guarantees

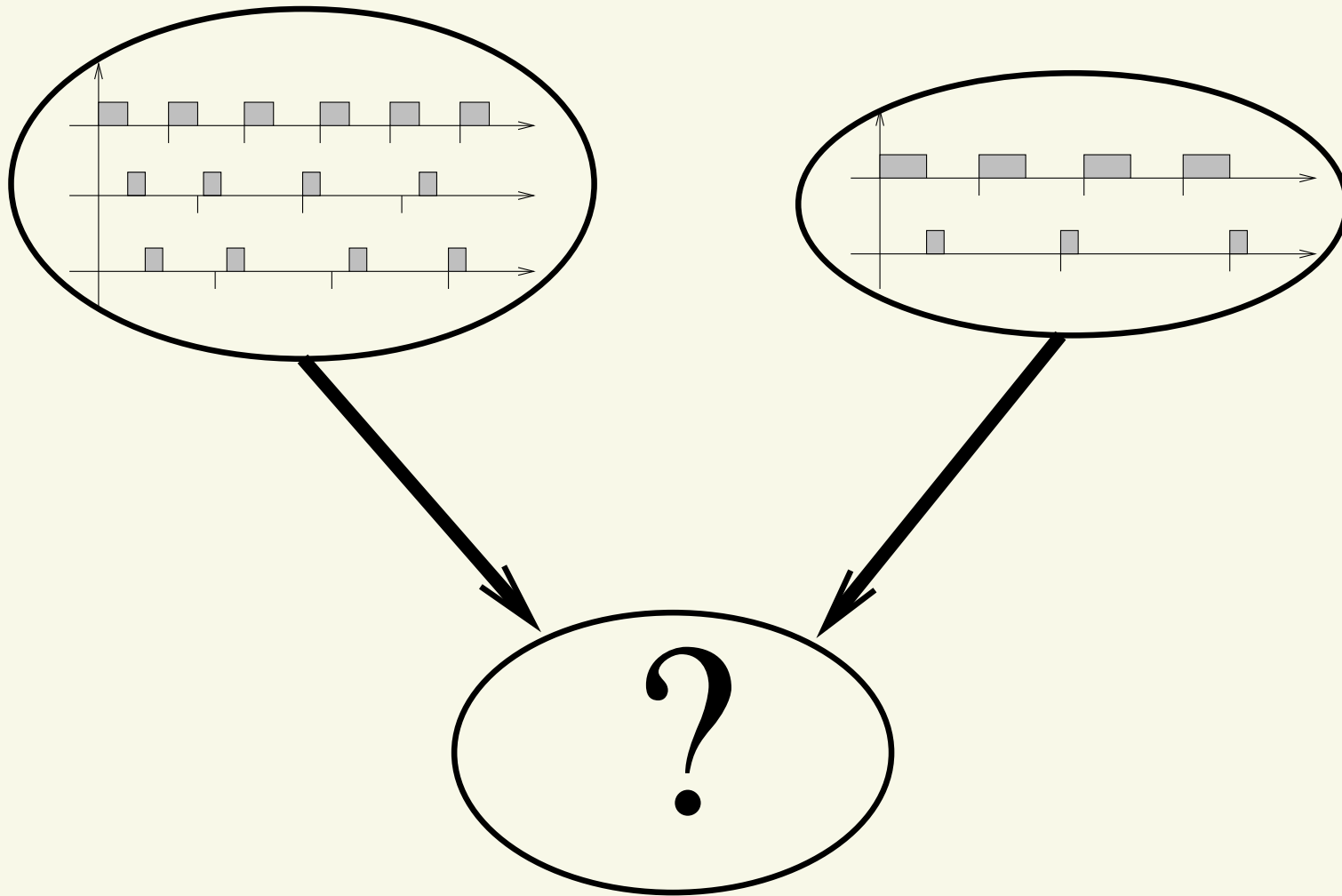

- Schedulability analysis in each VM...
- What about the resulting system?

Real-Time Applications Inside VMs

- VM \mathcal{C}^i contains n^i tasks
- How to analyze its schedulability?
 - We only know how to schedule single tasks...
 - And we need to somehow “summarise” the requirements of a VM!

$$\mathcal{C}^i = \{(C_0^i, D_0^i, T_0^i), (C_1^i, D_1^i, T_1^i), \dots, (C_{n^i}^i, D_{n^i}^i, T_{n^i}^i)\}$$

- So, 2 main issues:
 1. **Describe** the temporal requirements of a VM in a simple way
 2. **Schedule** the VMs, and somehow “**combine**” their temporal guarantees

The “not so smart” Solution

- Each VM is a set of real-time tasks:

$$\mathcal{C}^i = \{(C_j^i, D_j^i, T_j^i)\}$$

- Build the “global taskset” composed by all the tasks from all the VMs

$$\Gamma = \bigcup_i \mathcal{C}^i$$

- ...And use some known real-time scheduler (RM, EDF, ...) on Γ !

Flattened Scheduling

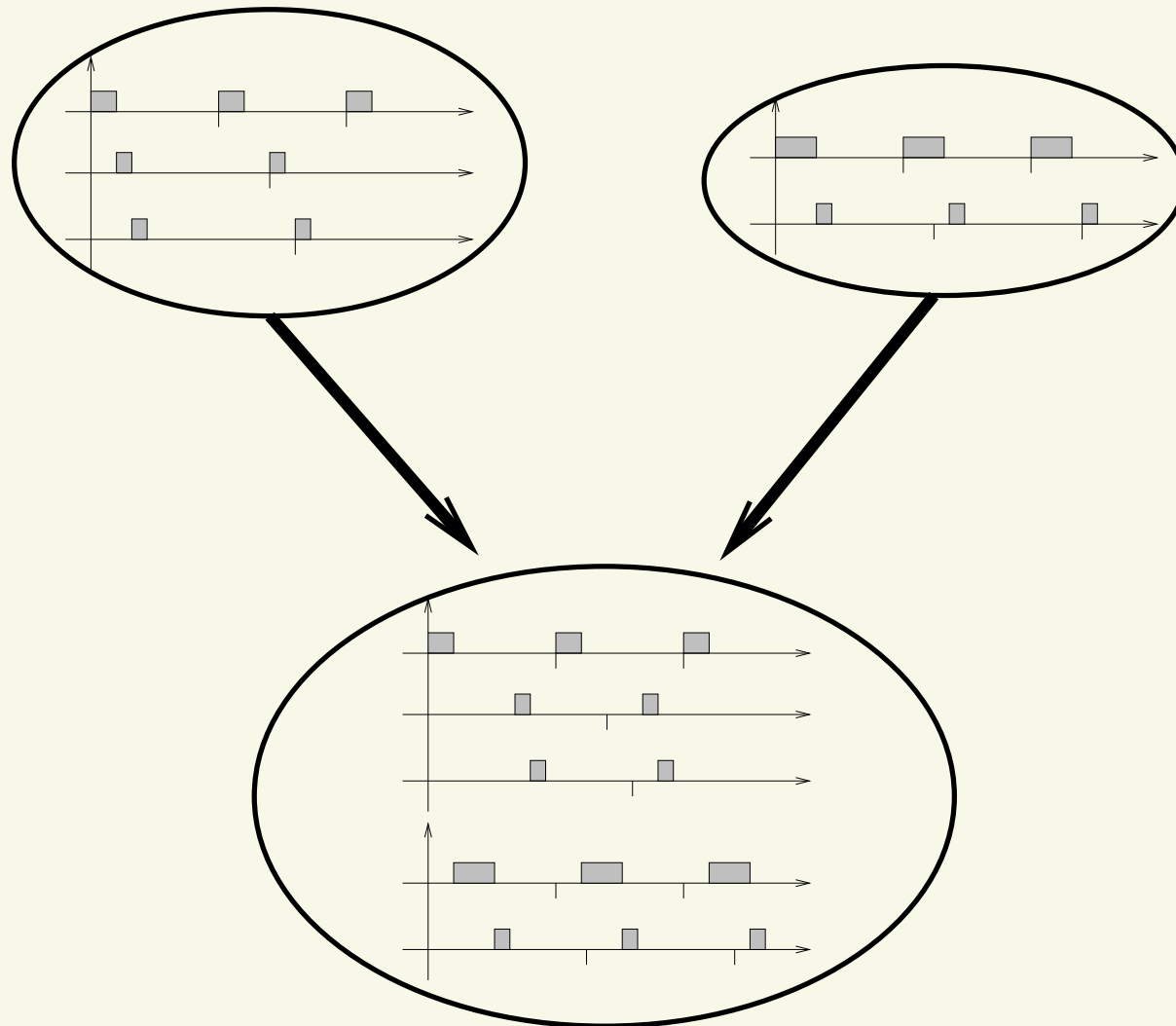

- One single “flattened” scheduler seeing all the tasks

Why it is “not so smart”

- One single scheduler, that must “see” all the tasks of all the VMs
 - Internals of the VMs have to be exposed!
 - VMs cannot run their own “local” schedulers
 - Misbehaving tasks in a VM can affect other VMs
 - **No isolation!!!**
- Using fixed priorities might be “not so simple”
 - Think about RM: priorities in a VM might depend on other VMs...

Practical Issues

- The host/hypervisor scheduler only sees VMs, but **cannot see the tasks inside** them
- Para-virtualization (of the OS scheduler) could be used to address this issue, but it is not so simple...
- ...And requires huge modifications to host, guest, and applications!
- So, how to schedule VMs?
- Two-level hierarchical scheduling system
 - Host (global / root) scheduler, scheduling VMs
 - Each VM contains its (local / 2nd level) scheduler

From a 1-Level Scheduler...

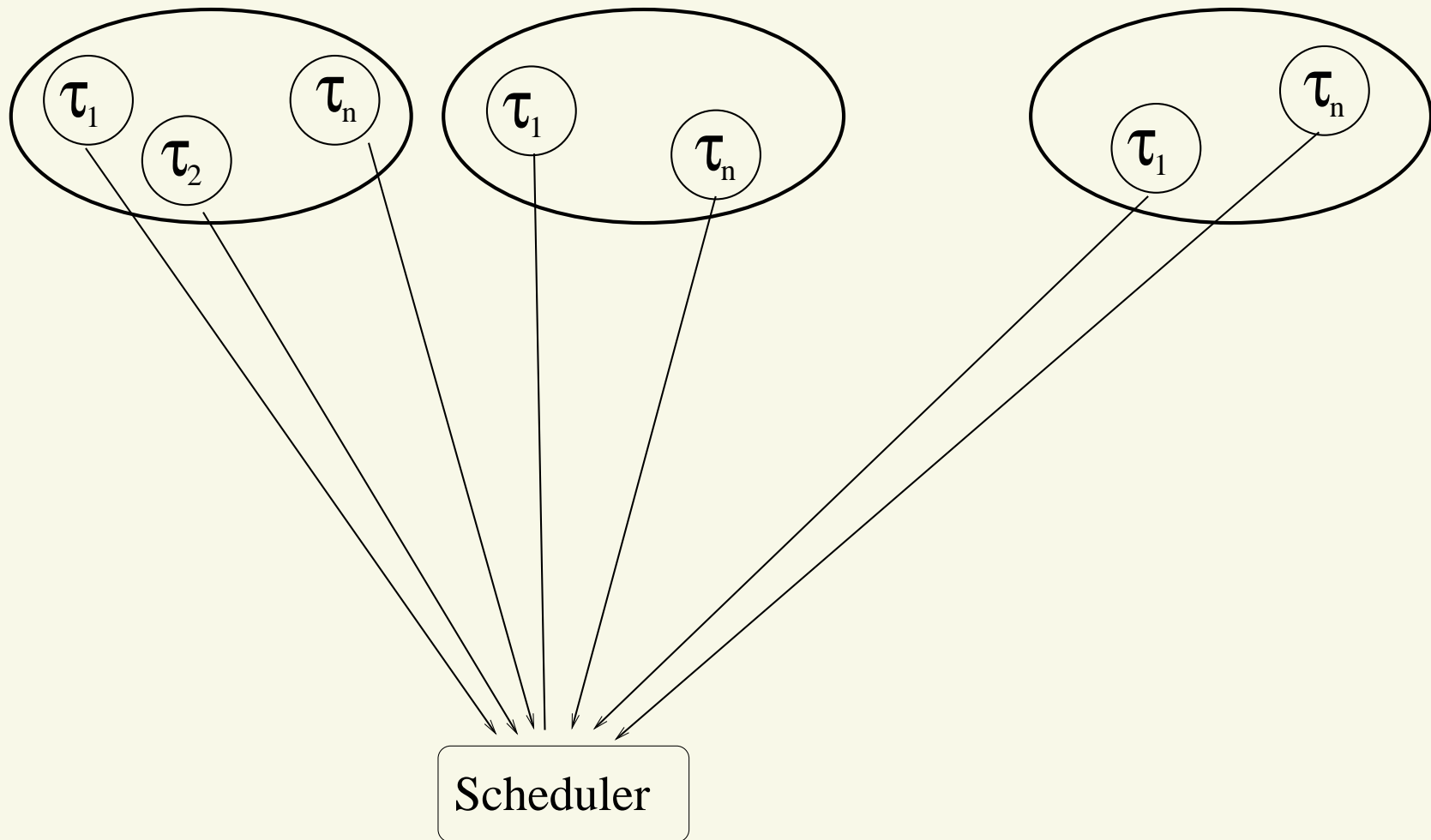

- Scheduler assigns CPU to tasks “inside the VMs”

...To a 2-Levels Hierarchy

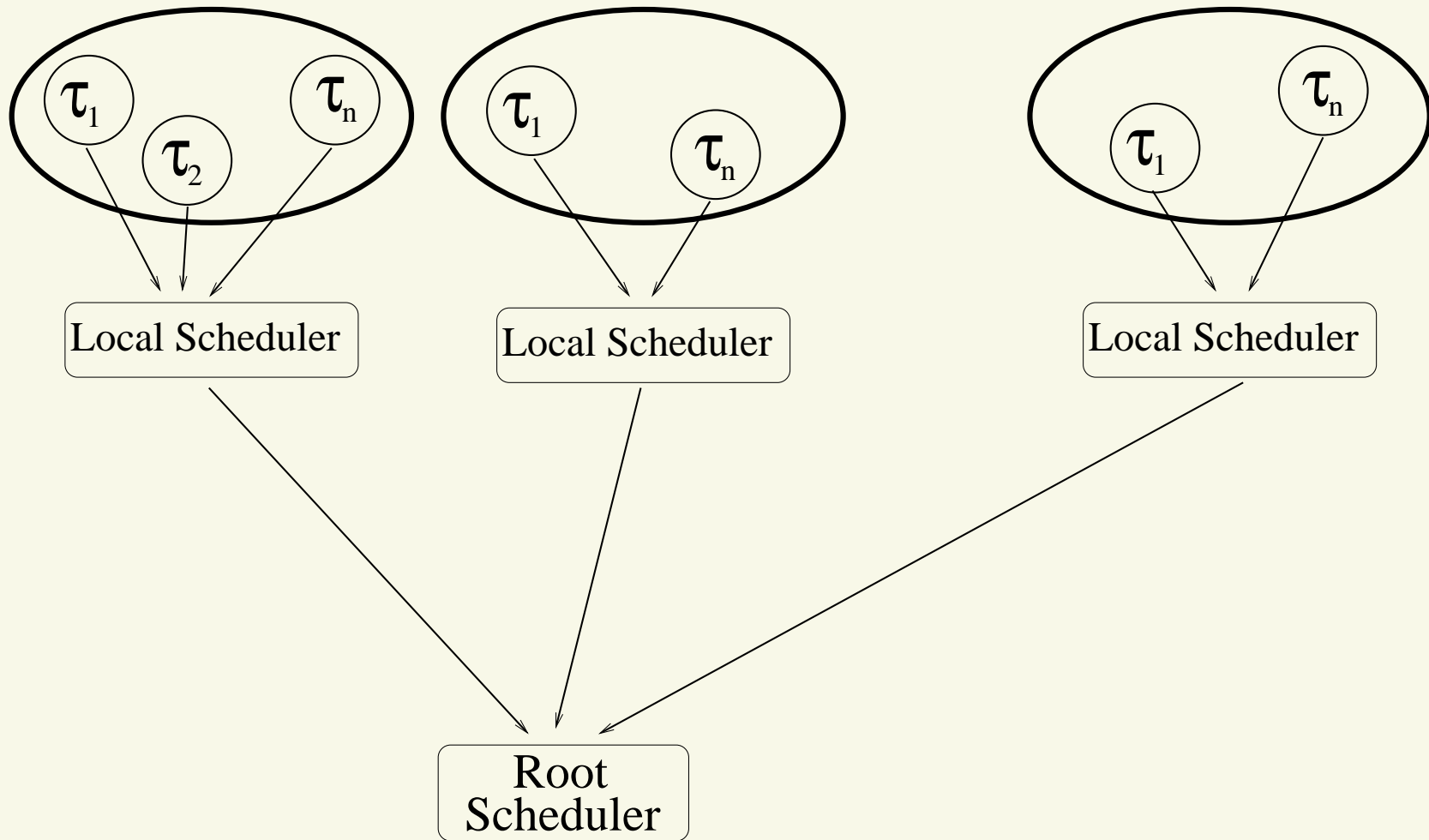

- Host Scheduler assigns CPU to VMs
- Local Schedulers assign CPU to single tasks

Hierarchical Scheduling

- The root scheduler does not see the tasks
- The OSs inside VMs are free to define their own (fixed priorities, EDF, whatever) schedulers
 - No problems in assigning fixed priorities to tasks!
- Root scheduler: host / hypervisor scheduler
- Local scheduler: guest scheduler
- Problem: what to use as a root scheduler?
 - We must have a model for it
 - Must allow to compose the “local guarantees”
- Which are the requirements for RT schedulability analysis?

Real-Time Guarantees for Virtualized Applications

- First requirement: analyse the schedulability of each guest independently from the others
 - This means that the root scheduler must provide some kind of **temporal protection** between VMs
- Various possibilities
 - Resource Reservations / server-based approach
 - Static time partitioning
 - ...
- In any case, **the root scheduler must guarantee that each VM receives a minimum amount of resources in a time interval**

Schedulability Analysis: the Basic Idea

- (Over?)Simplifying things a little bit...
- ...Suppose to know the amount of time needed by a VM to respect its temporal constraints and the amount of time provided by the root scheduler
- A virtualized application is “schedulable” if

$$\text{demanded time} \leq \text{supplied time}$$

- “demanded time”: amount of time (in a time interval) needed by the application
- “supplied time”: amount of time (in a time interval) given by the root scheduler to the VM hosting it
- Of course **the devil is in the details**

Demanded Time

- Amount of time needed by a VM to respect its temporal constraints
 - Depends on the time interval we are considering
 - Depends on the VM's local scheduler
 - EDF $\rightarrow dbf(t) = \sum_j \max\{0, \left\lfloor \frac{t+T_j-D_j}{T_j} \right\rfloor\} C_j$
 - RM: \rightarrow workload $W(t) = C_i + \sum_{j<i} \left\lfloor \frac{t}{T_i} \right\rfloor C_j$
 - Note: $W(t)$ is very pessimistic, $dbf(t)$ is not
- This is the description of the temporal requirements of a VM we were searching for...
- And what about the supplied time?

Supplied Time

- Description of the root scheduler temporal behaviour
- More formally:
 - Depends on the time interval t we are considering
 - Depends on the root scheduler \mathcal{A}
- Minimum amount of time given by \mathcal{A} to a VM in a time interval of size s
 - Given all the time intervals $(t_0, t_1) : t_1 - t_0 = s \dots$
 - ...Compute the size of the sub-interval in which $\sigma(t) = VM \dots$
 - ...And then find the minimum!

Supplied Time Bound Function

- Even more formally:
 - Define $s(t) = \begin{cases} 1 & \text{if } \alpha(t) = VM \\ 0 & \text{otherwise} \end{cases}$
 - Time for VM in $(t_0, t_0 + s)$: $\int_{t_0}^{t_0+s} s(t) dt$
 - Then, compute the minimum over t_0
- $sbf(t) = \min_{t_0} \int_{t_0}^{t_0+t} s(x) dx$

Example: Static Time Partitioning

- First (very simple) example of VM scheduling: static time partitioning
 - Static schedule describing when time is assigned to each VM
 - Pre-computed $\sigma(t)$
- Generally, periodic!
 - Otherwise, need to store an infinite schedule...
 - ...Might be problematic!
- Example: $VM_{\mathcal{A}}$ is scheduled in $(3, 4)$, $(9, 10)$, $(15, 16)$, ...
 - More formally: $s(t) = 1$ if $6k + 3 \leq t \leq 6k + 4$,
 $s(t) = 0$ otherwise

Example: Static Time Partitioning - 2

$$s(t) = \begin{cases} 1 & \text{if } 6k + 3 \leq t \leq 6k + 4 \\ 0 & \text{otherwise} \end{cases}$$

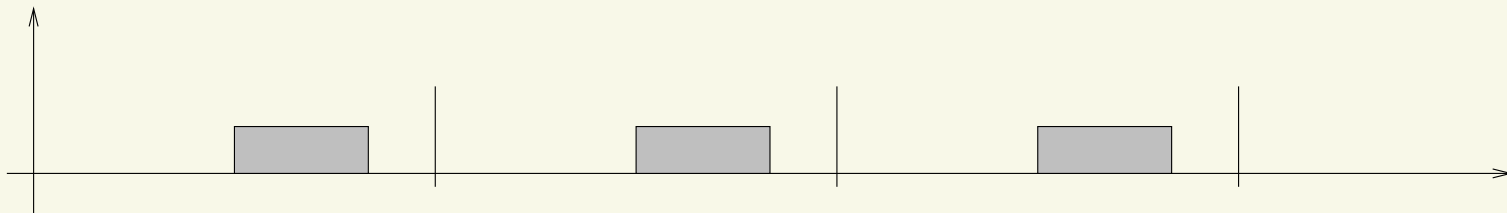

- What is the supply bound function $sbf(t)$ in this case?
- Let's try different supply functions compatible with this schedule...
- ...And see what is the worst case!
 - Intervals of size t starting at different times...

Example: Static Time Partitioning - 3

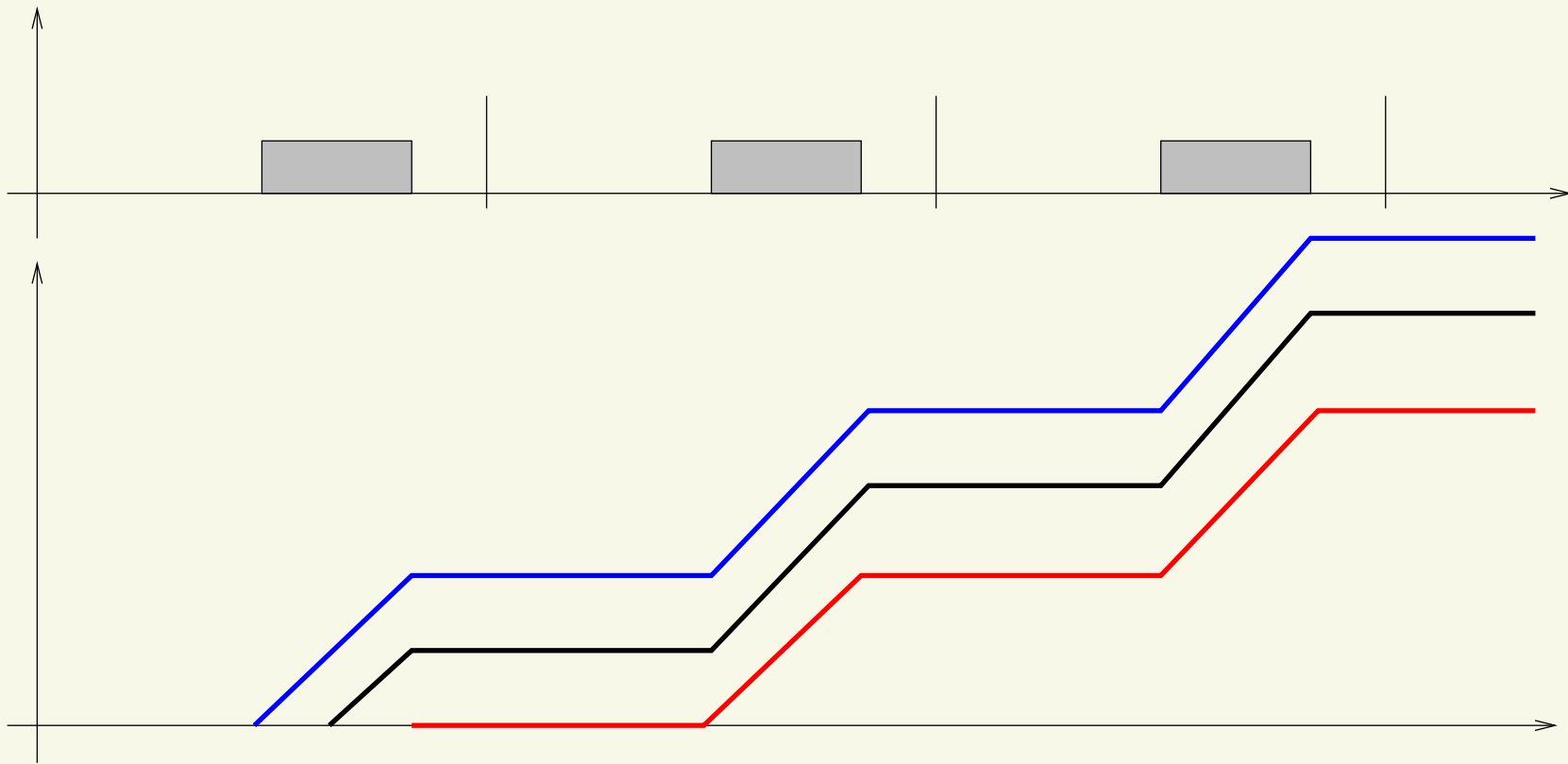

- Different supply functions depending on when the considered interval begins
- Which one is the worst case (supply **bound** function)?

Example: Static Time Partitioning - 4

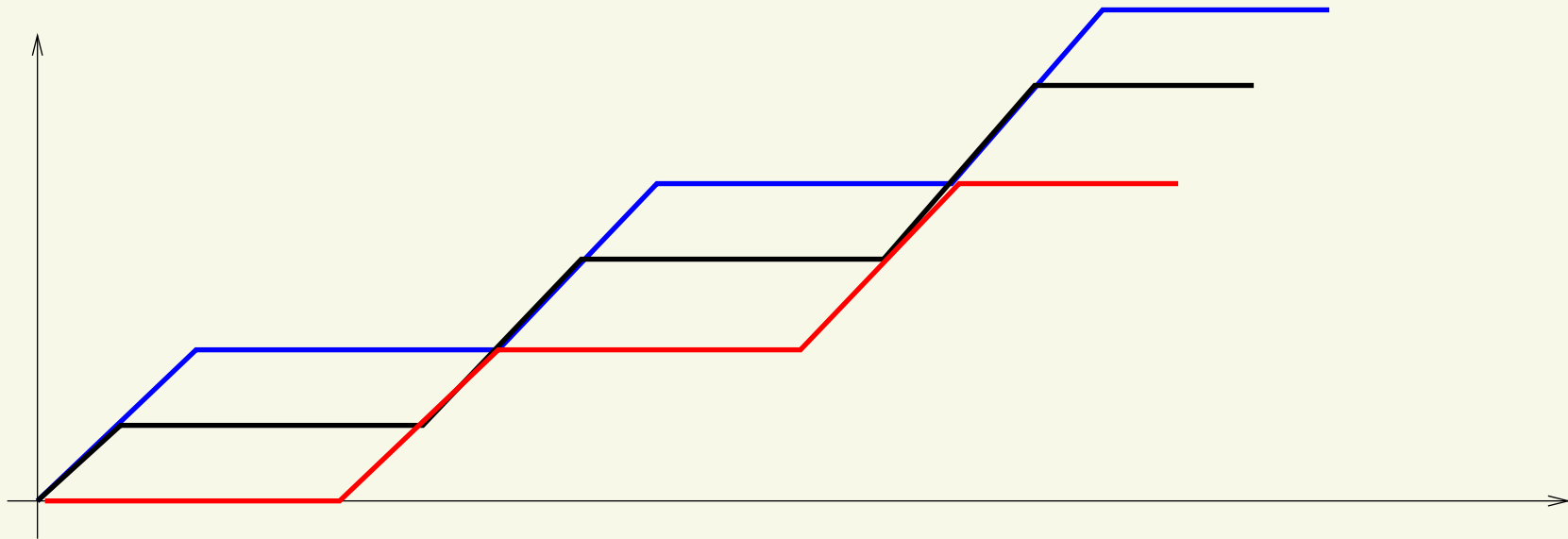

- Different supply functions depending on when the considered interval begins
- Which one is the worst case (supply **bound** function)?
 - The red one!

Example: Static Time Partitioning - 5

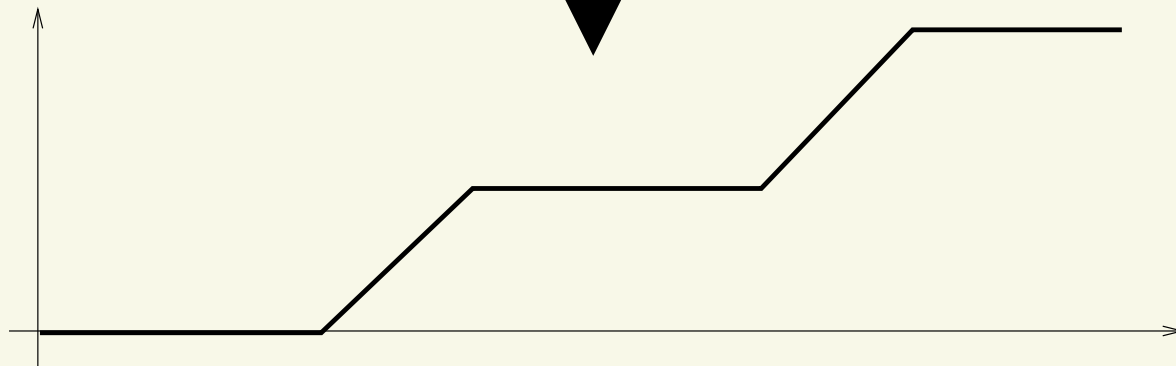
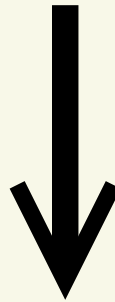
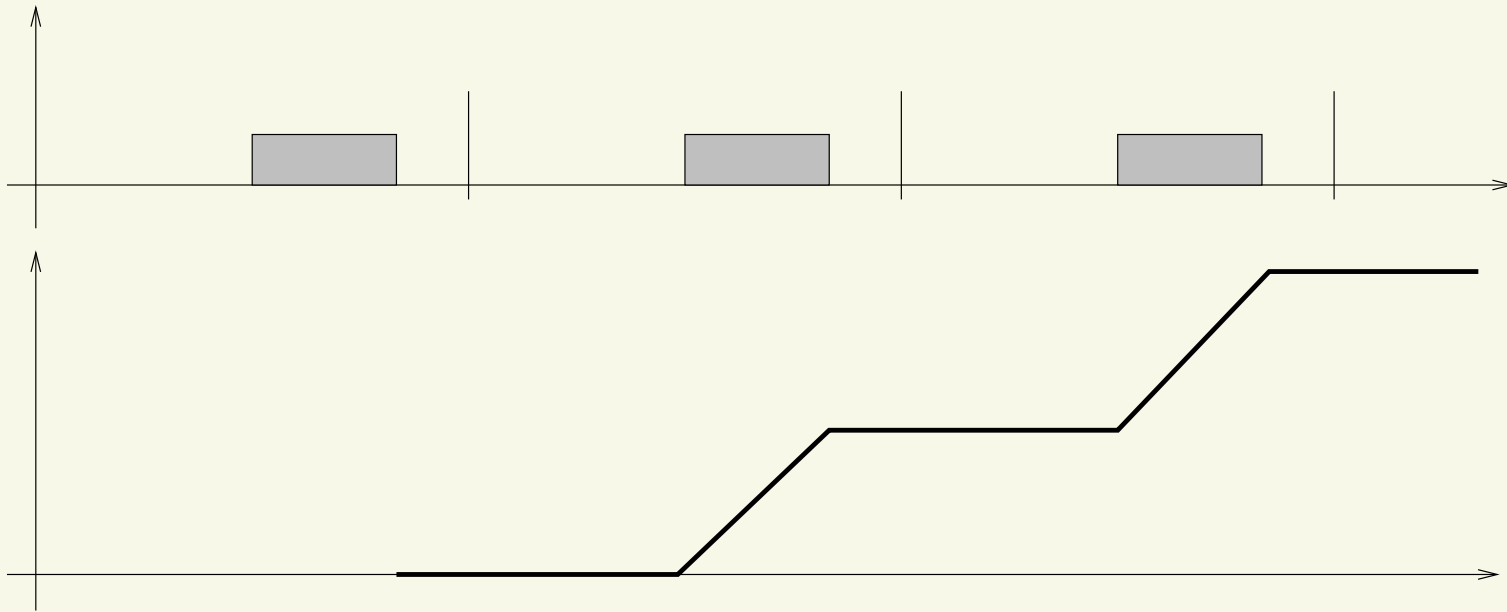

Periodic Servers

- Periodic Server $\mathcal{S} = (Q, P)$: guarantees Q units of time every period P
 - Can be implemented in different ways (example: CBS)
- Different from static allocation: we do not know where in the period the Q time units are allocated
 - Execution inside a period can even be preempted!

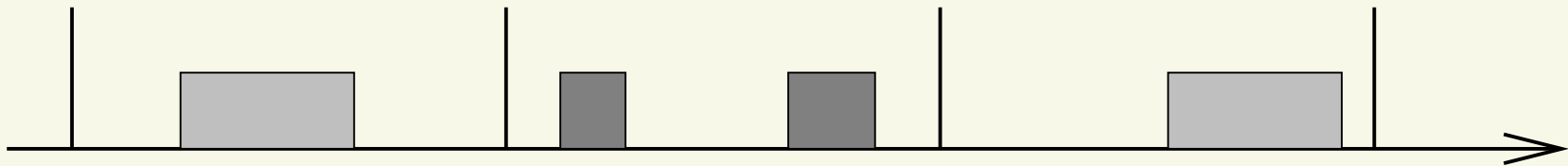

Periodic Servers — Supplied Time

- $sbf(t)$: minimum amount of time that a VM is guaranteed to receive in a time interval of size t
 - Consider all the possible intervals of size t ...
 - As already seen for static time partitioning
 - ...And all the possible “legal CPU allocations” generated by the periodic server!
- Big difference with static time partitioning: consider all the possible allocations of Q in the period

The Wrong Solution

- Imagine Q is allocated at the beginning of the period
- Worst case allocation: t_0 immediately after Q
- The time interval starts when the root scheduler deschedules the VM

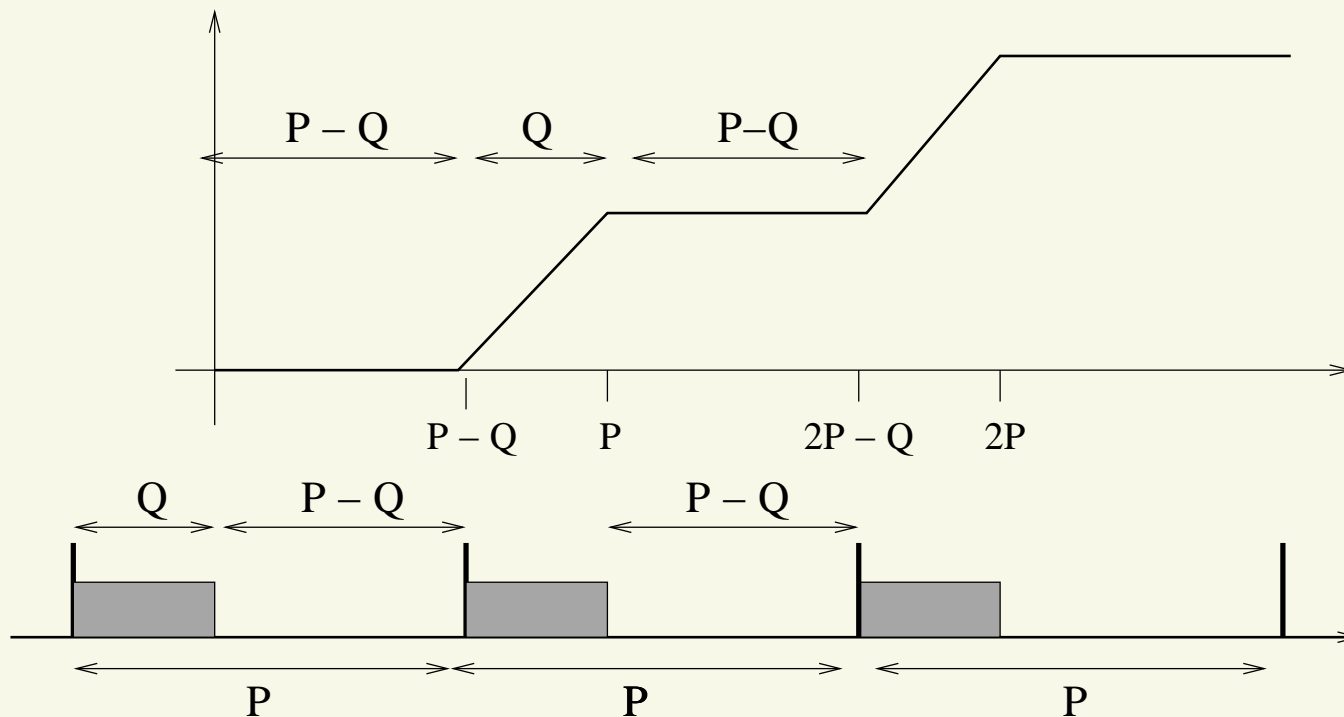

The Wrong Solution — 2

- Supplied time: 0 until $P - Q$...
- ...Then increases with slope 1 until P ...
- ...Then flat again until $2P - Q$...
- ...

$$sbf(t) = \begin{cases} 0 & \text{if } t < (P - Q) \\ (n - 1)Q & \text{if } (n - 1)P \leq t < nP - Q \\ t + nQ - (n - 1)P & \text{if } nP - Q \leq t < nP \end{cases}$$

Why Wrong?

- The previous computation assumed Q always at the beginning of a period...
- ...But this is not the worst case!
 - Think about the second period...
 - ...What happens if the root scheduler delays the allocation?
 - The initial “0 allocation period” increases!!!
- Worst-case schedule: Q at the beginning of the first period and at the end of the second one
 - See the difference with static time partitioning?

Considering the Worst-Case Situation

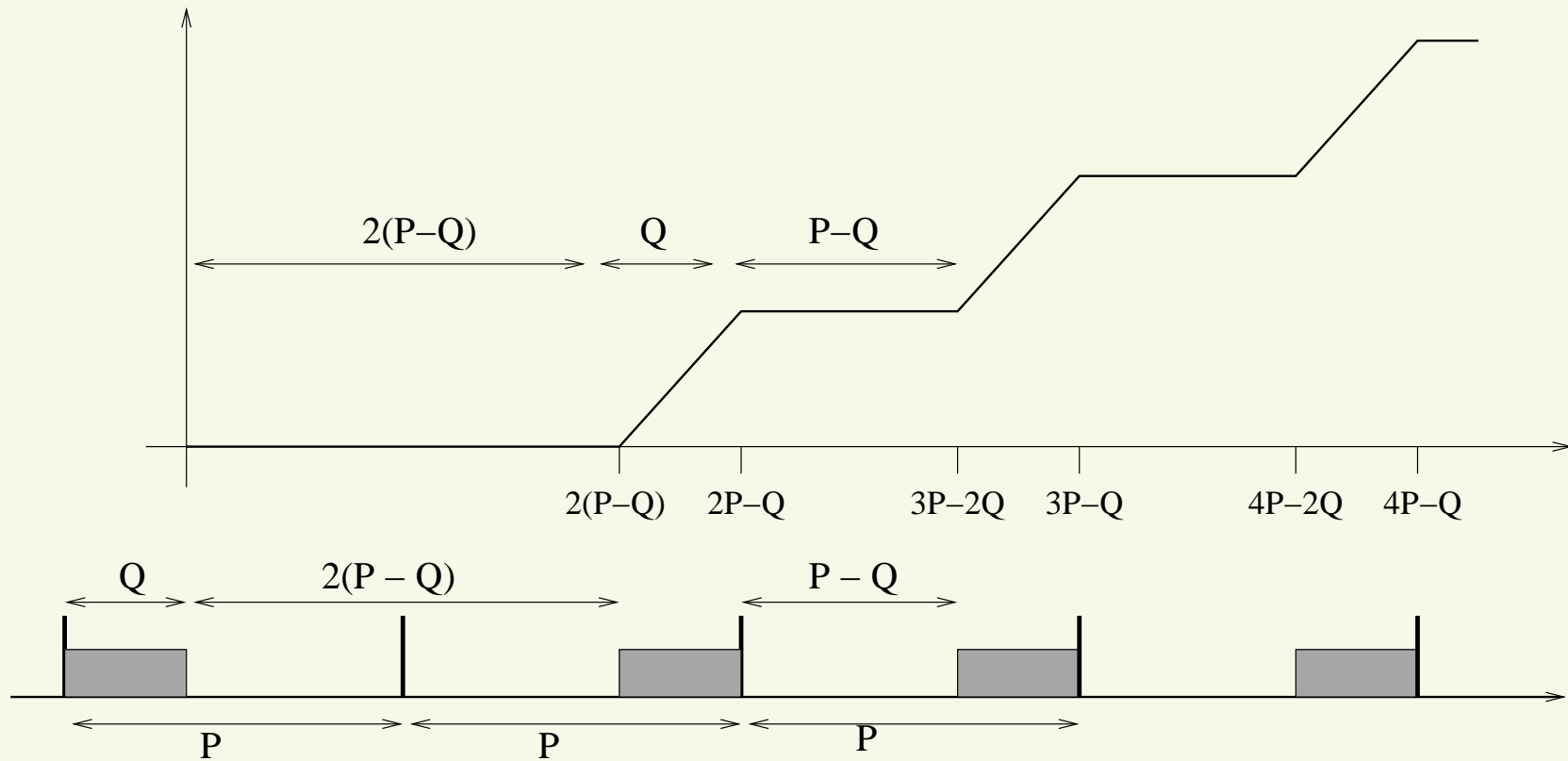

$$sbf(t) = \begin{cases} 0 & \text{if } t < 2(P - Q) \\ (n - 1)Q & \text{if } nP - Q \leq t < (n + 1)P - 2Q \\ t - (n + 1)(P - Q) & \text{if } (n + 1)P - 2Q \leq t < (n + 1)P - Q \end{cases}$$

Understanding the Supplied Bound Function

- Supplied bound function $sbf(t)$: minimum amount of time that a VM is guaranteed to receive in a time interval of size t
 - Considers all the possible intervals of size t ...
- Strange looking function!
 - Flat for large intervals of time...
 - $\frac{\delta sbf(t)}{\delta t} = 1$ in the other intervals
- Can we “summarise” it with something simpler?
- What about a line ($y = ax + b$)?
 - $sbf(t) < 0$ makes no sense...
 - So, better $sbf(t) = \max\{0, at + b\}$

A Linear Approximation

- $sbf(t) = \max\{0, at + b\}$... $at + b$ is below 0 for $t < -b/a$
- Let's rewrite the equation... $at + b = a(t - \Delta)$ with $\Delta = -b/a$

$$sbf(t) = \begin{cases} 0 & \text{if } t < \Delta \\ a(t - \Delta) & \text{otherwise} \end{cases}$$

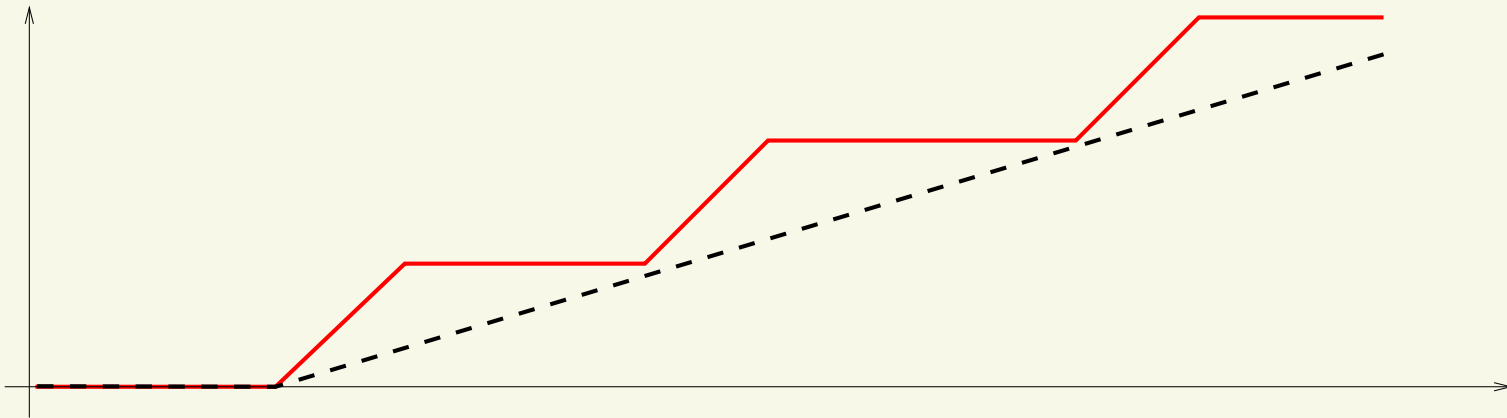

Interpreting the Linear Approximation

- $t < \Delta \Rightarrow sbf(t) = 0$: Δ is the *allocation delay* for the VM
 - Worst-case delay between the VM becoming active and the root scheduler scheduling it
 - How much time should I wait before the root scheduler starts giving the CPU to my VM?
- a (sometimes referred as α) is the *bandwidth* of the VM
 - Minimum fraction of CPU time reserved for the VM **after the initial delay**
- Of course, (a, Δ) should be so that $a(t - \Delta)$ is below the real $sbf()$

Periodic Servers Revisited

- How to compute (a, Δ) for a periodic server (Q^s, T^s) ?
 - $a = \frac{Q^s}{T^s}, \Delta = 2(T^s - Q^s)$
- So, after the initial delay $2(T^s - Q^s)$ the VM is really receiving the expected fraction of CPU time (Q^s/T^s)
 - If we reduce T^s (keeping Q^s/T^s unchanged)...
 - ... $sbf(t)$ tends to the “fluid allocation”!
- Why not using very very small server periods?
 - Of course there is a reason...

The Design Problem

- Given a VM (running a set of tasks and a local scheduler)...
 - Described by a time demand function (workload for fixed priorities)
- ...Find a root scheduler (and scheduling parameters) able to respect the tasks' temporal constraints
- Problem reduced to solving “ $sbf(t) \geq dbf(t)$ ” for a set of points
 - Must be verified for all the points in case of EDF
 - Must be verified for at least one point in case of fixed priorities

Simplified Design

- $sbf(t) \geq dbf(t)$
- Using $sbf(t) = a(t - \Delta) \dots$

$$a(t - \Delta) \geq dbf(t) \Rightarrow \Delta \leq t - \frac{dbf(t)}{a}$$

- Solve this for every $(t, dbf(t))$, and plot the solution on a $a - \Delta$ plane...
- ...Then compute the intersection (for EDF) or union (for fixed priorities)